

REINHOLD ENVIRONMENTAL Ltd.



**2013 APC Round Table
& Expo Presentation**

July 8-9, 2013, in St. Louis, MO / Hosted by Ameren

All presentations posted on this website are copyrighted by Reinhold Environmental, Ltd (RE). Any unauthorized downloading, attempts to modify or to incorporate into other presentations, link to other websites, or obtain copies for any other uses than the training of attendees to RE's Conferences is expressly prohibited, unless approved in writing by RE or the original presenter. RE does not assume any liability for the accuracy or contents of any materials contained in this library which were presented and/or created by persons who were not employees of RE.



URS



2013 APCIPUG Conference

GORE™ Mercury Control System Updates

Jeff Kolde: W.L. Gore and Associates, Inc.

Jonas Klingspor: URS Corporation

Outline

- GMCS Technology Overview
- Installation Approach
- Pilot test results
- Full-scale test plans
- Economic analysis
- Future plans



GORE™ Mercury Control System (GMCS)

- Different approach to mercury control
 - Fixed Sorbent System
 - Tailpipe solution
- Multi-Pollutant Control Capabilities



Sorbent Polymer Composite (SPC)

- Proprietary Fluoropolymer Material developed at Gore
 - Efficiently captures both elemental and oxidized mercury
 - Very high capacity for mercury storage
 - Long module lifetime
 - SO₂ is converted into sulfuric acid
 - SO₂ removal co-benefit
 - Hydrophobic structure prevents “flooding” and expels acid to outer surface of SPC
 - Does not require regeneration

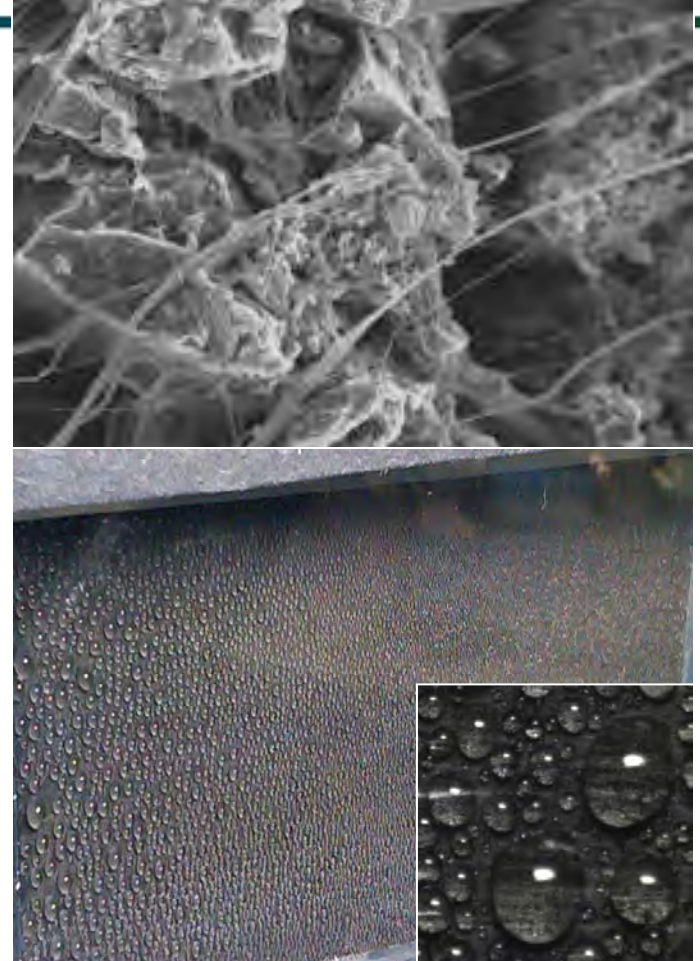

Sorbent Polymer Composite (SPC)

Mercury Control Module

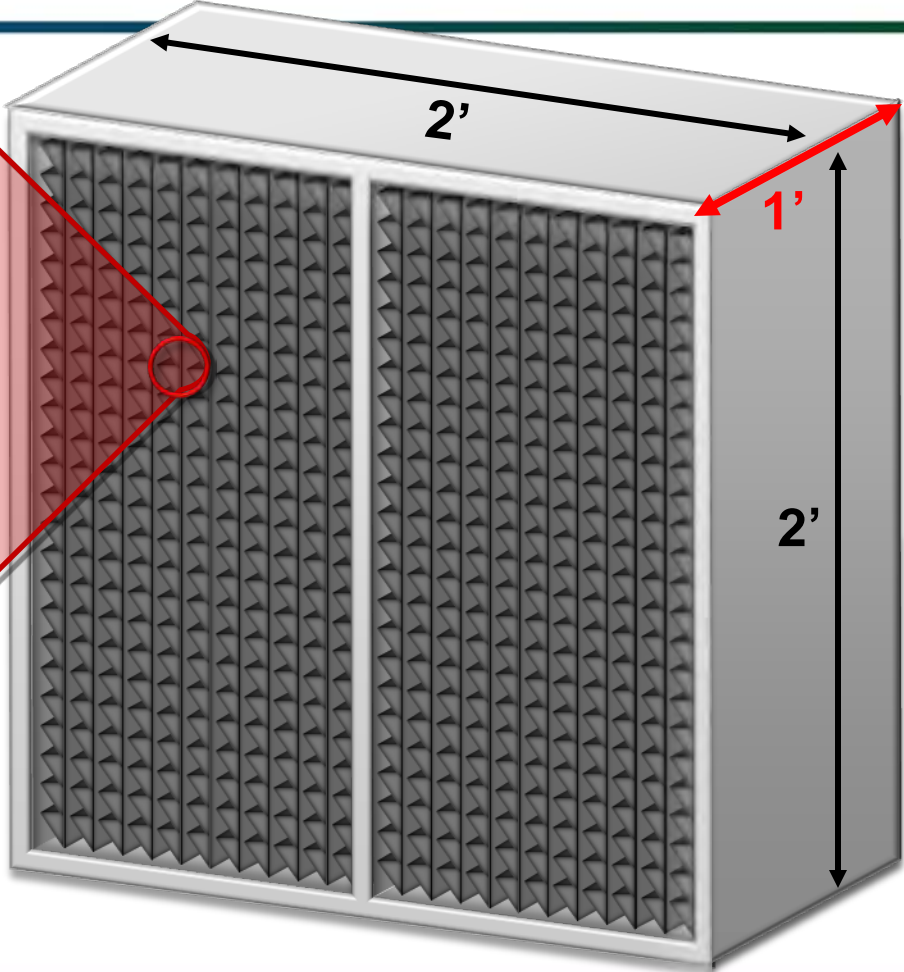
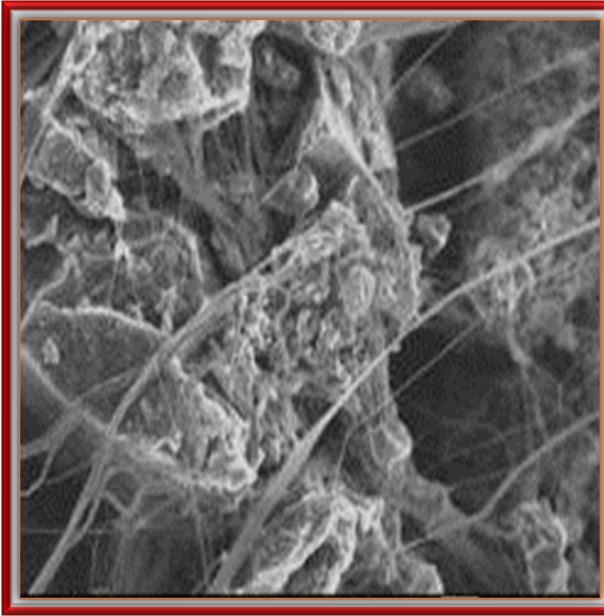

Discrete Modules

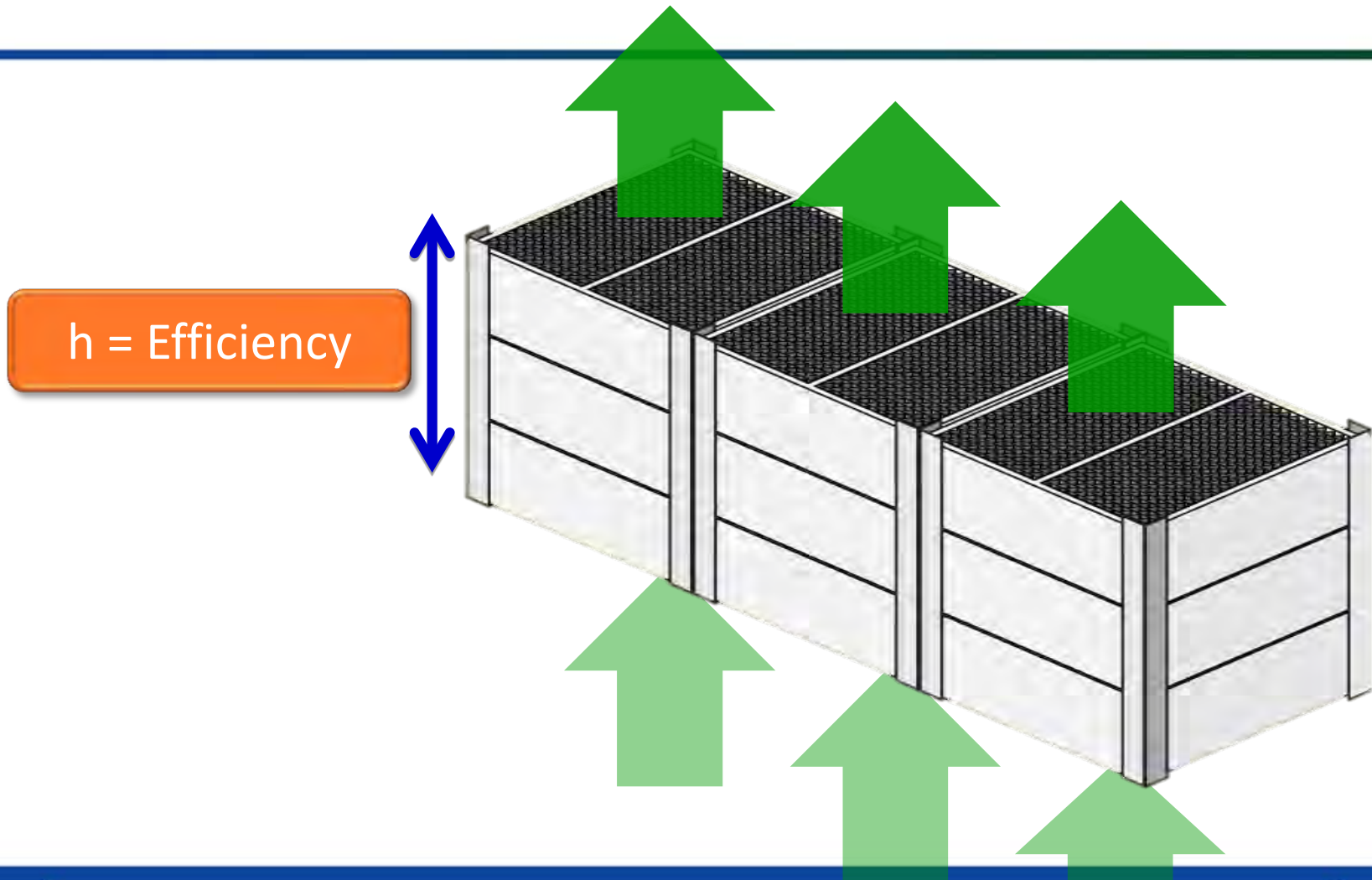

Module Design Features

- Low Pressure Drop
- Fouling resistance

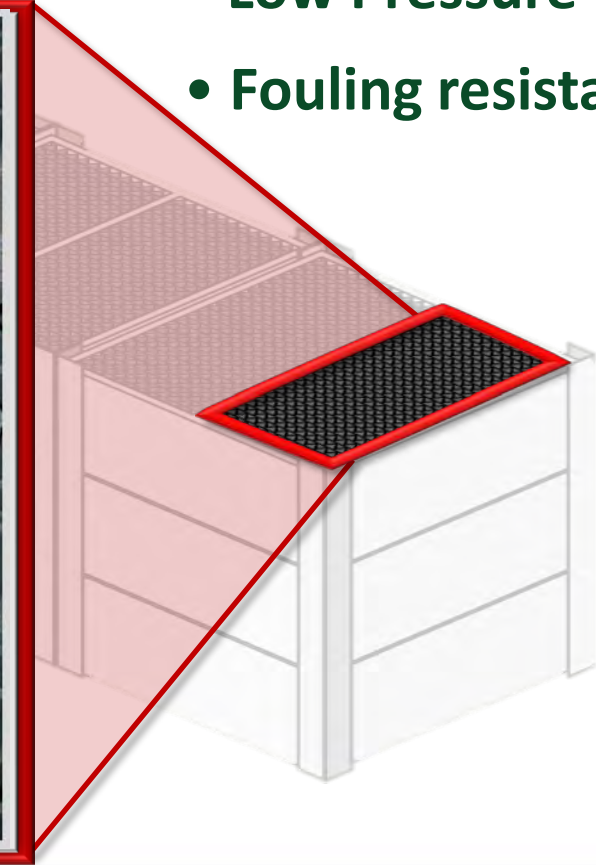
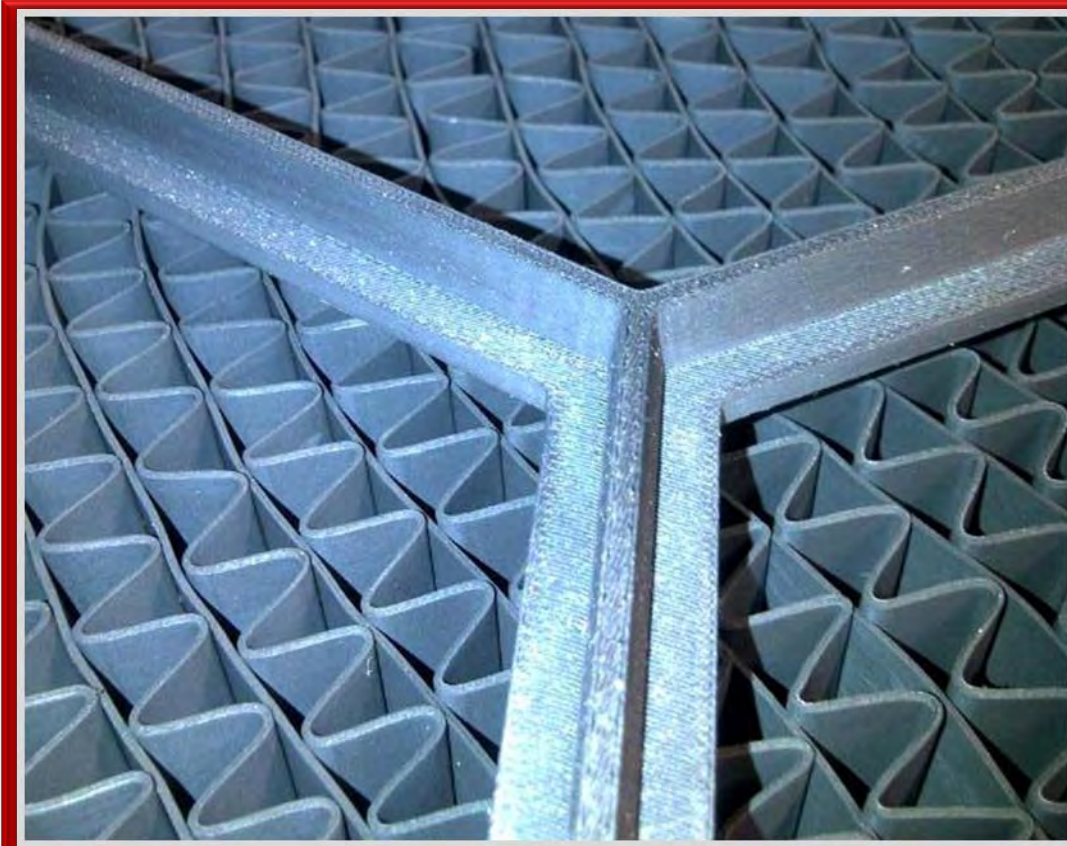

Mechanisms

Open channels provide low pressure drop and fouling resistance

SO₂ oxidized by SPC material and forms H₂SO₄

Hg is strongly bound to SPC material (chemisorption)

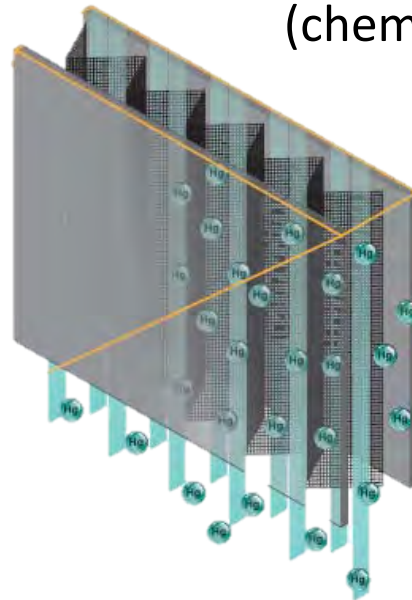

Continuous acid wash + PTFE-rich SPC surface resists fouling by carryover

H₂SO₄ is expelled to the surface and falls into the absorber reaction tank



Pressure Drop Across Single Module

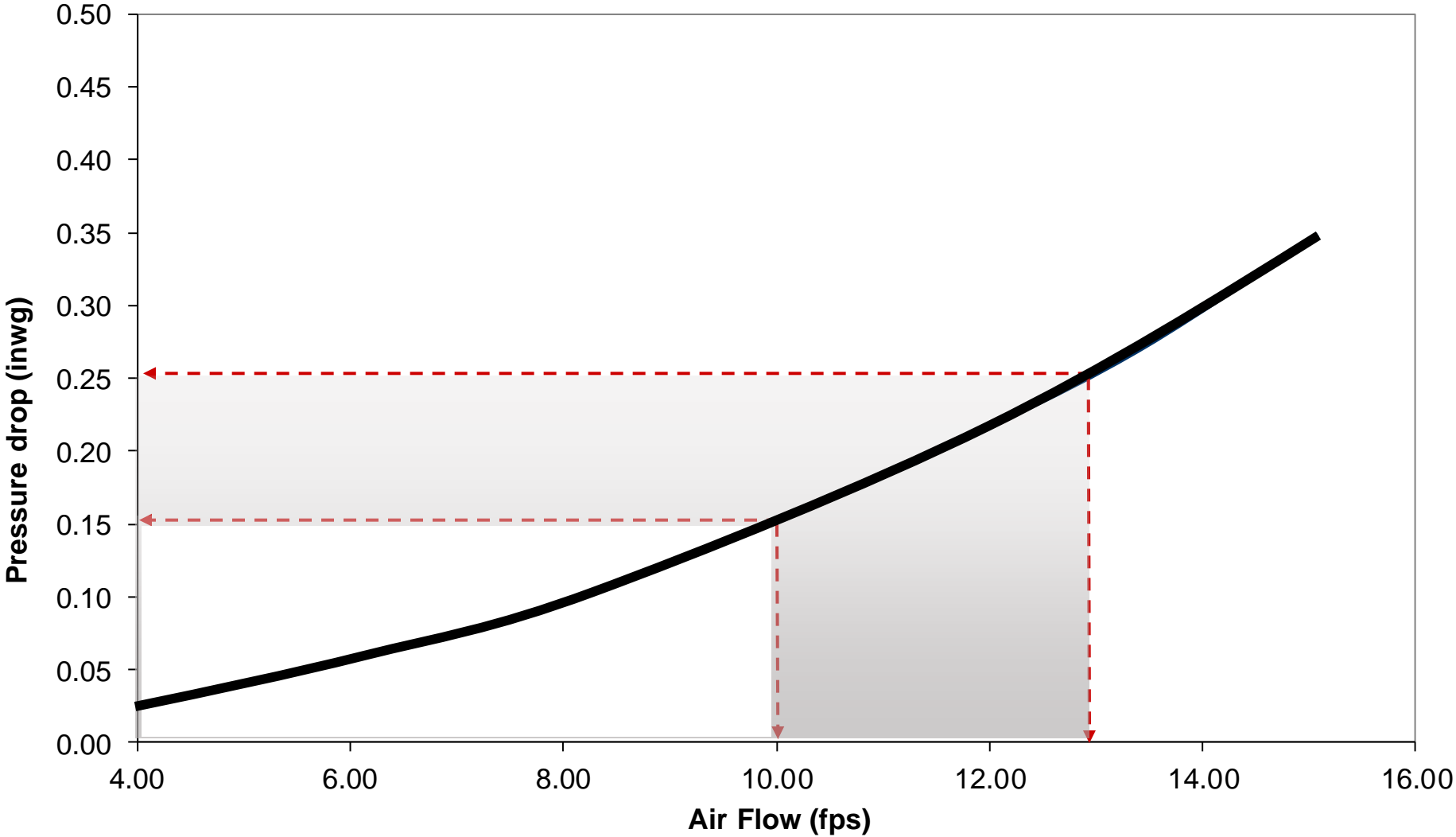

2013 APC/PCUG Conference



GMCS Fixed Sorbent System

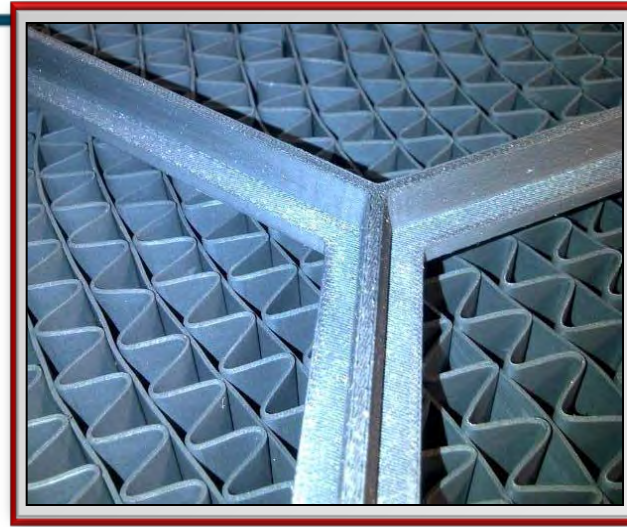

- ✓ Low Impact
- ✓ Simple Operation
- ✓ Robust
- ✓ Cost Effective



GMCS Fixed Sorbent System

Unlike Carbon Injection:

- No fly ash contamination
- No additional strain on collector
- No SO₃ sensitivity
- Lower solid waste generation / lower disposal costs
- Simple to operate – no adjustments needed, minimal supply logistics



GMCS Fixed Sorbent System

Unlike Bromine Injection:

- No risk of bromine-induced corrosion (APH, wFGD)
- No waste-water treatment system impact (Br, Se)
- Post-scrubber installation: Hg re-emissions barrier



GMCS Fixed Sorbent System

Unlike Traditional Fixed Sorbent Beds:

- Low Pressure Drop
- No need to pre-treat gas (RH and acid gas insensitive)
- No regeneration required



Testing of Fixed Beds after Wet Scrubber

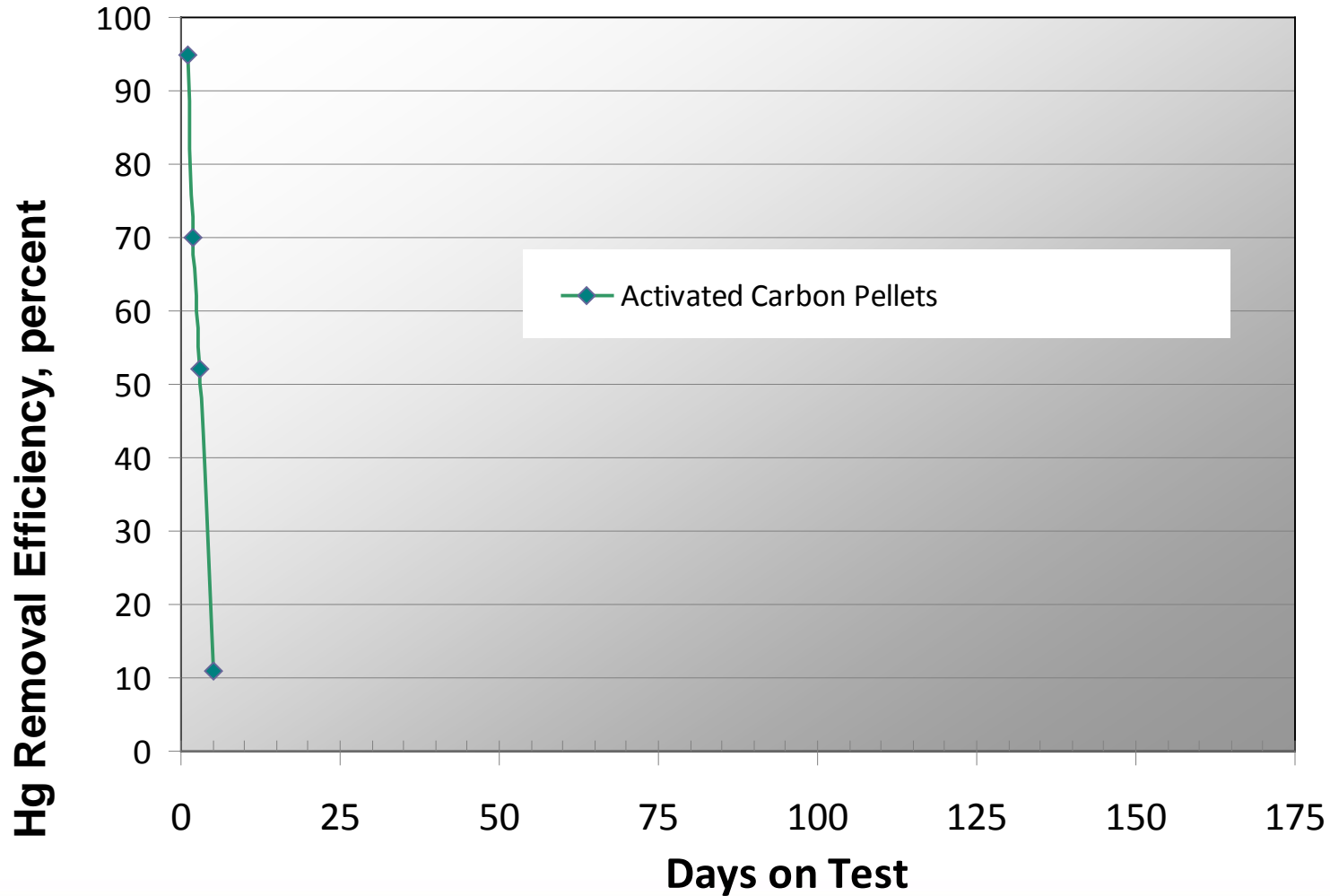

Testing of Fixed Beds after Wet Scrubber

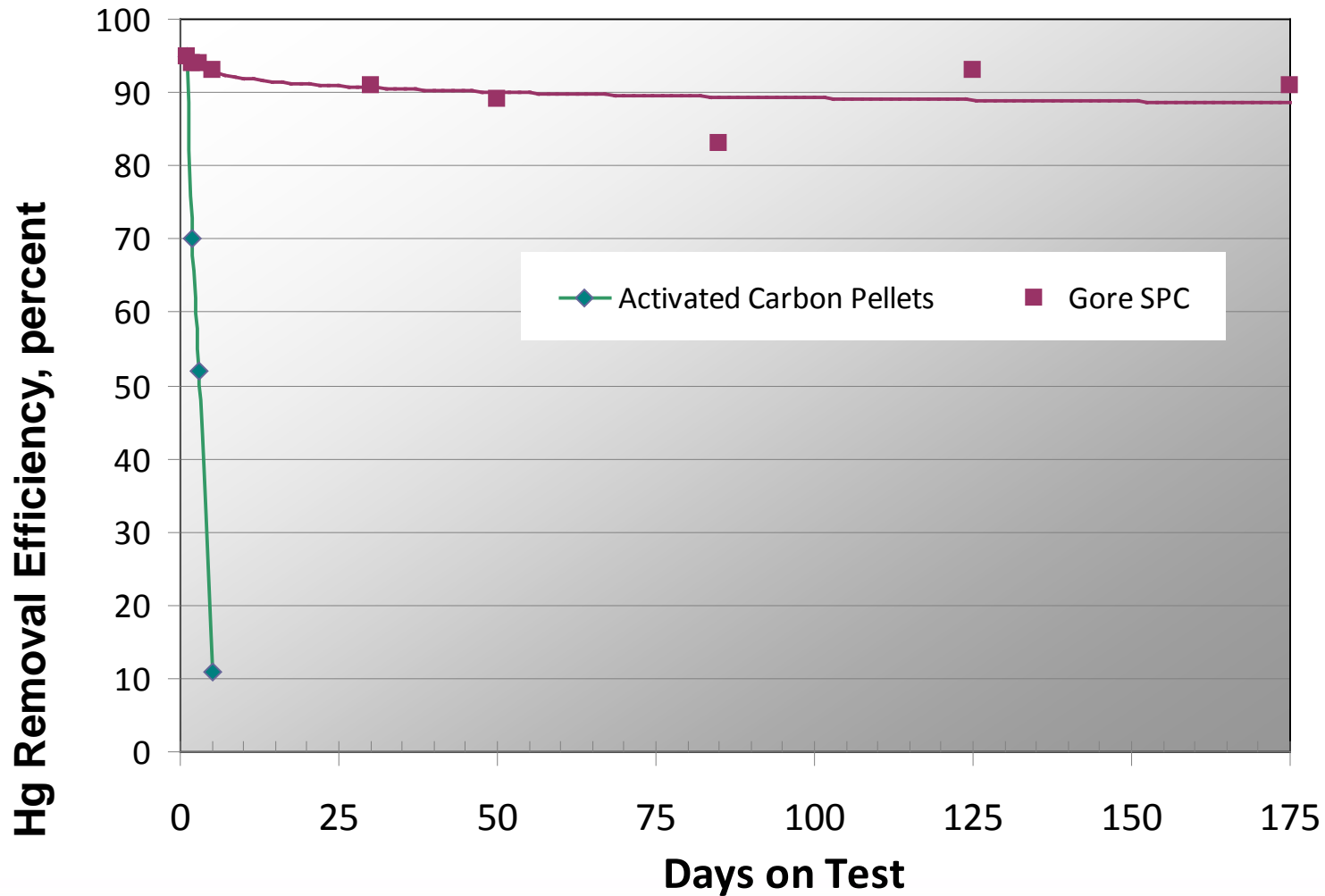

Scalable Mercury Control

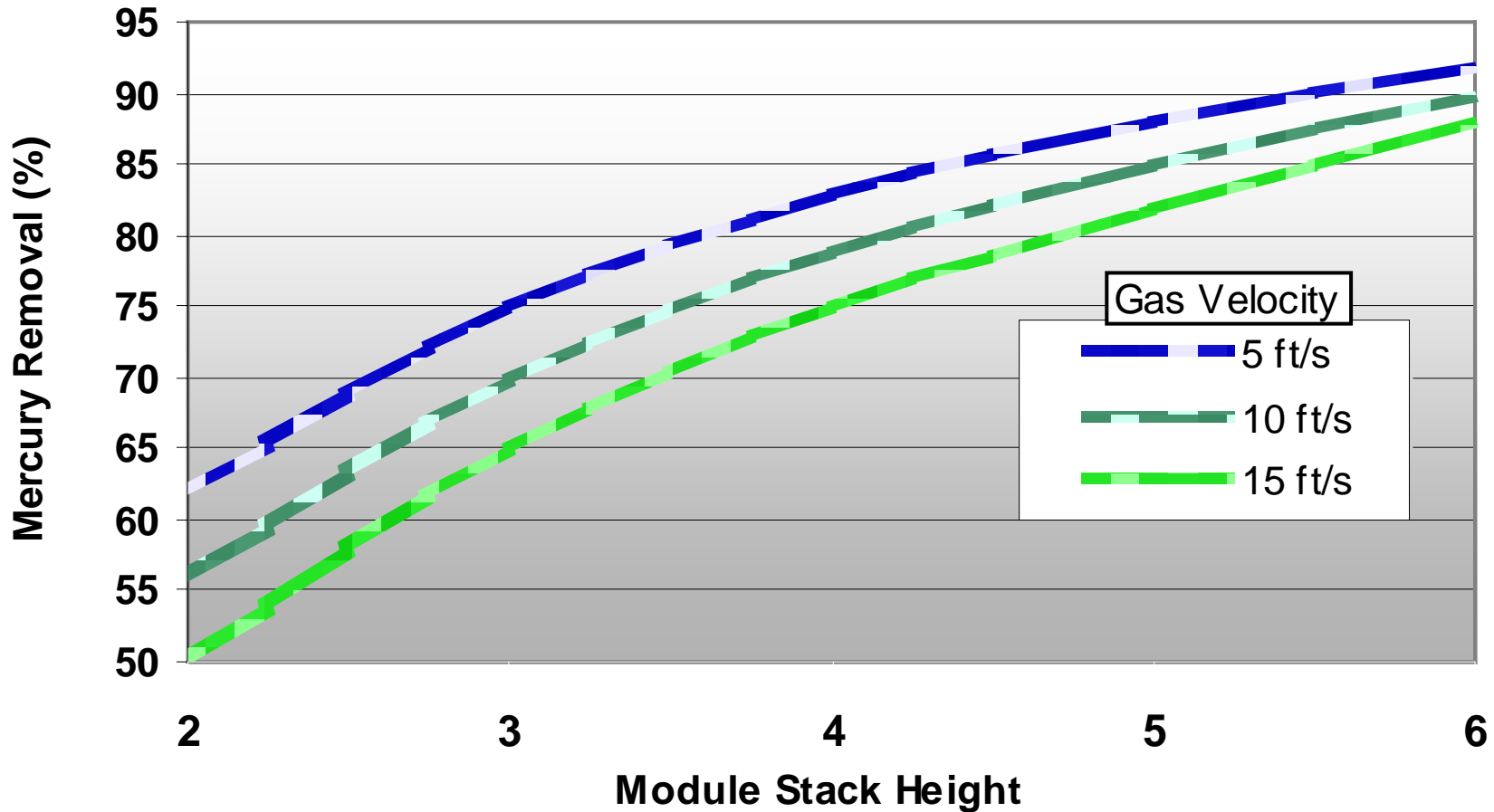

Installation in Wet Scrubber*

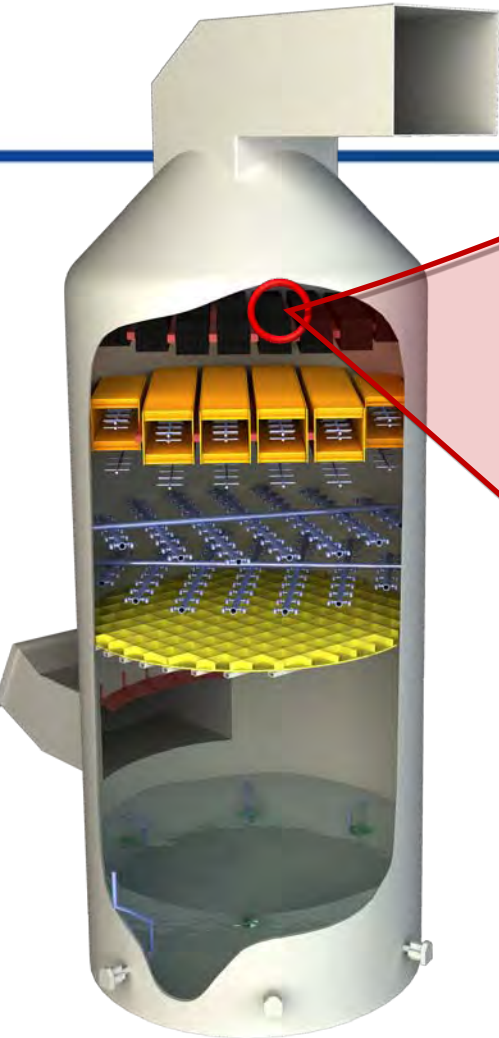

“Zero-footprint” approach

Application patents licensed from EPRI

URS



2013 APC/PCUG Conference



Lifetime Projections

- Extensive field testing over past several years has not yet reached the point of module capacity
- Accelerated testing to determine SPC capacity
 1. Rapid mercury dosing of SPC (high concentration)
 2. Test Hg-removal efficiency in flowing cell



Module Lifetime

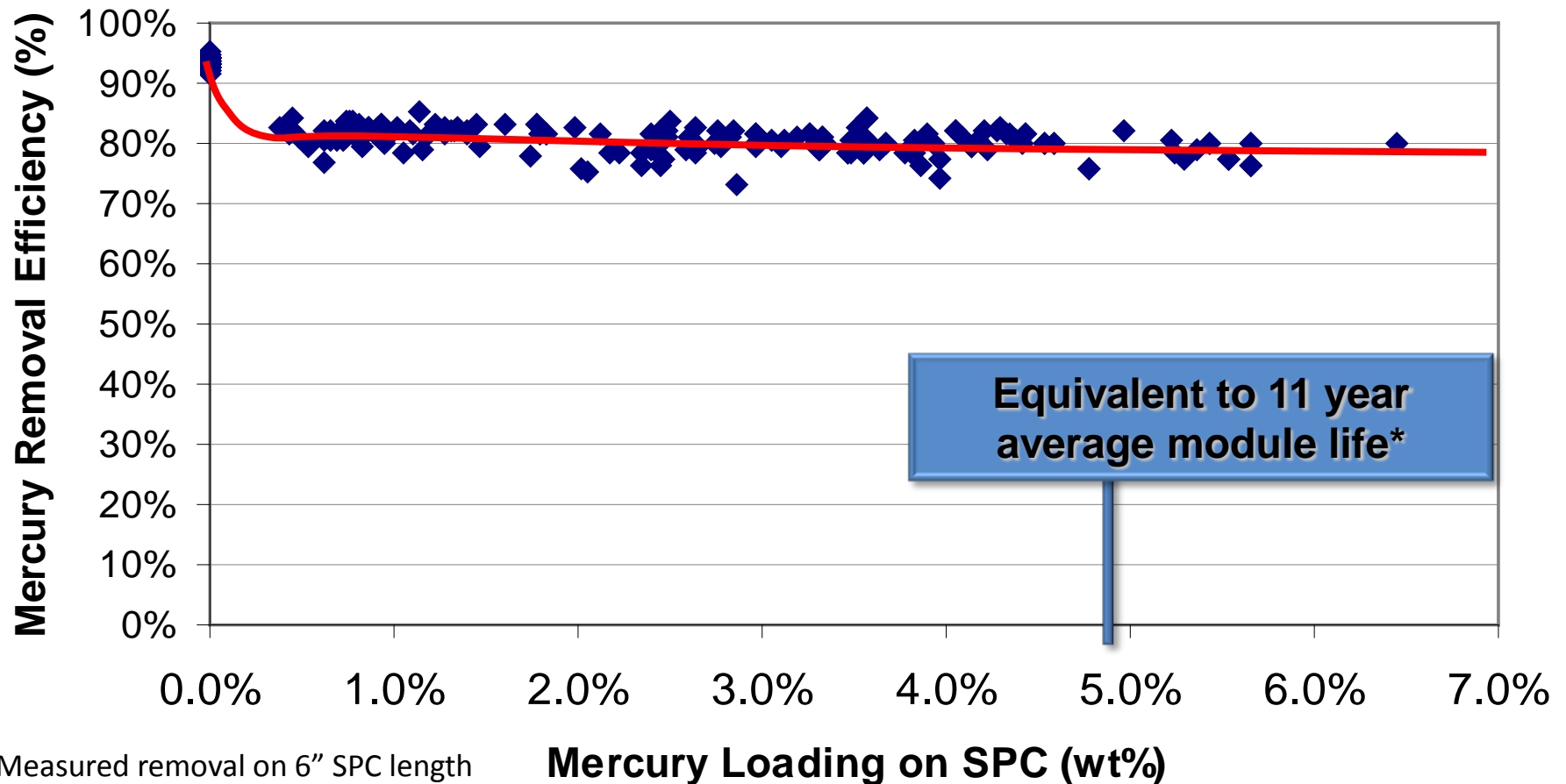

Measured removal on 6" SPC length scaled to 48" removal efficiency

Mercury Loading on SPC (wt%)

* Plant needing 75% reduction to meet 1.2 lb Hg/TBtu



2013 APC/PCUG Conference



Multi-pollutant Control System

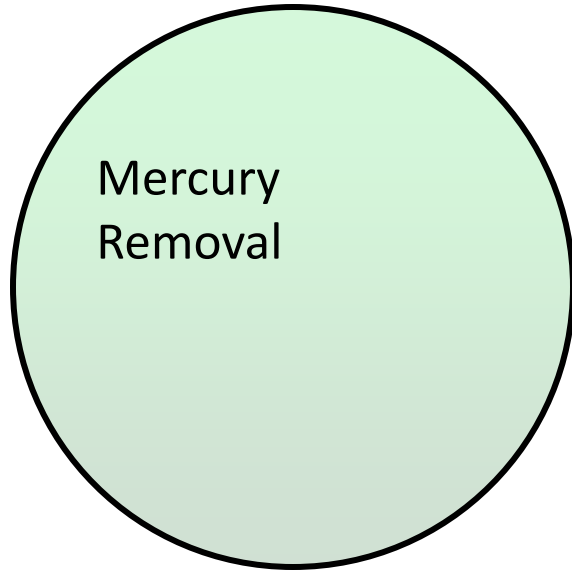

All 3 attributes are
scalable and tunable

Hg: Elemental and
Oxidized mercury capture

Multi-pollutant Control System

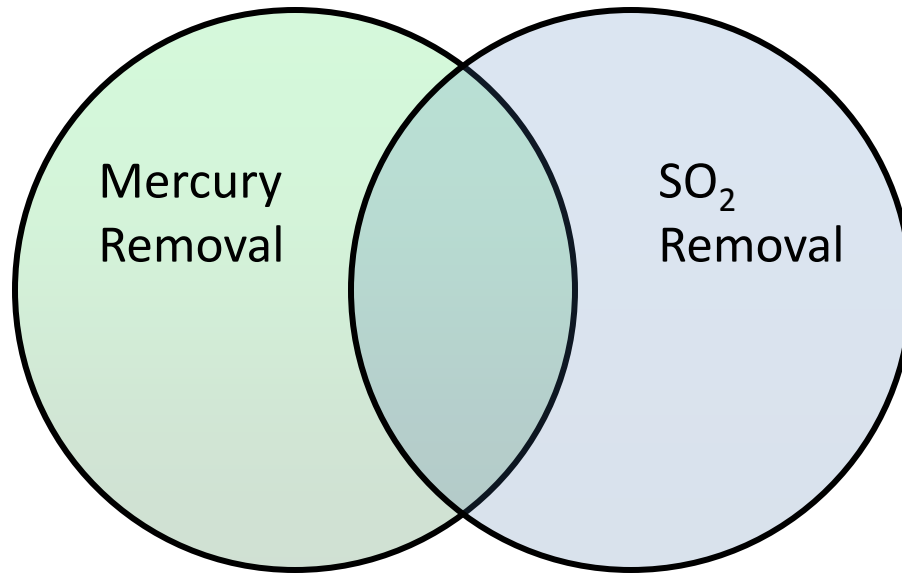

All 3 attributes are scalable and tunable

Hg: Elemental and Oxidized mercury capture

SO₂: Typical SO₂ removal of 50-70% measured in field trials



Multi-pollutant Control System

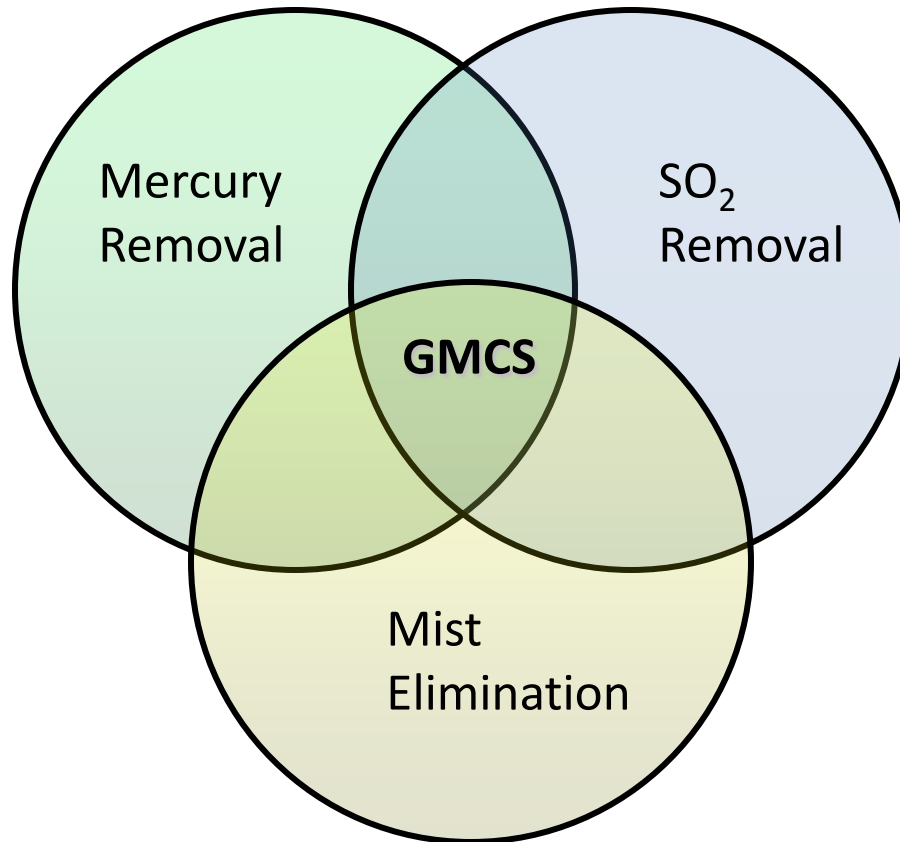

All 3 attributes are scalable and tunable

Hg: Elemental and Oxidized mercury capture

SO₂: Typical SO₂ removal of 50-70% measured in field trials

ME: >80% of 1-10 micron liquid droplets captured

Module Disposal

C276 Tray
Re-used



SPC Media
Consumable

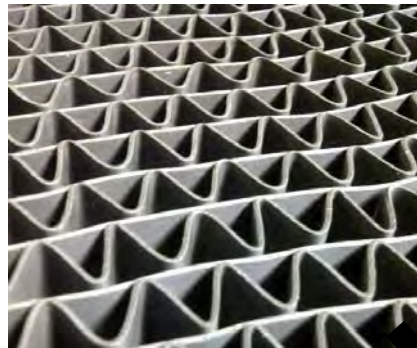

SPC Media from one entire module (2'x2'x1') – compact shipping/disposal



Comparison of ACI and SPC Disposal

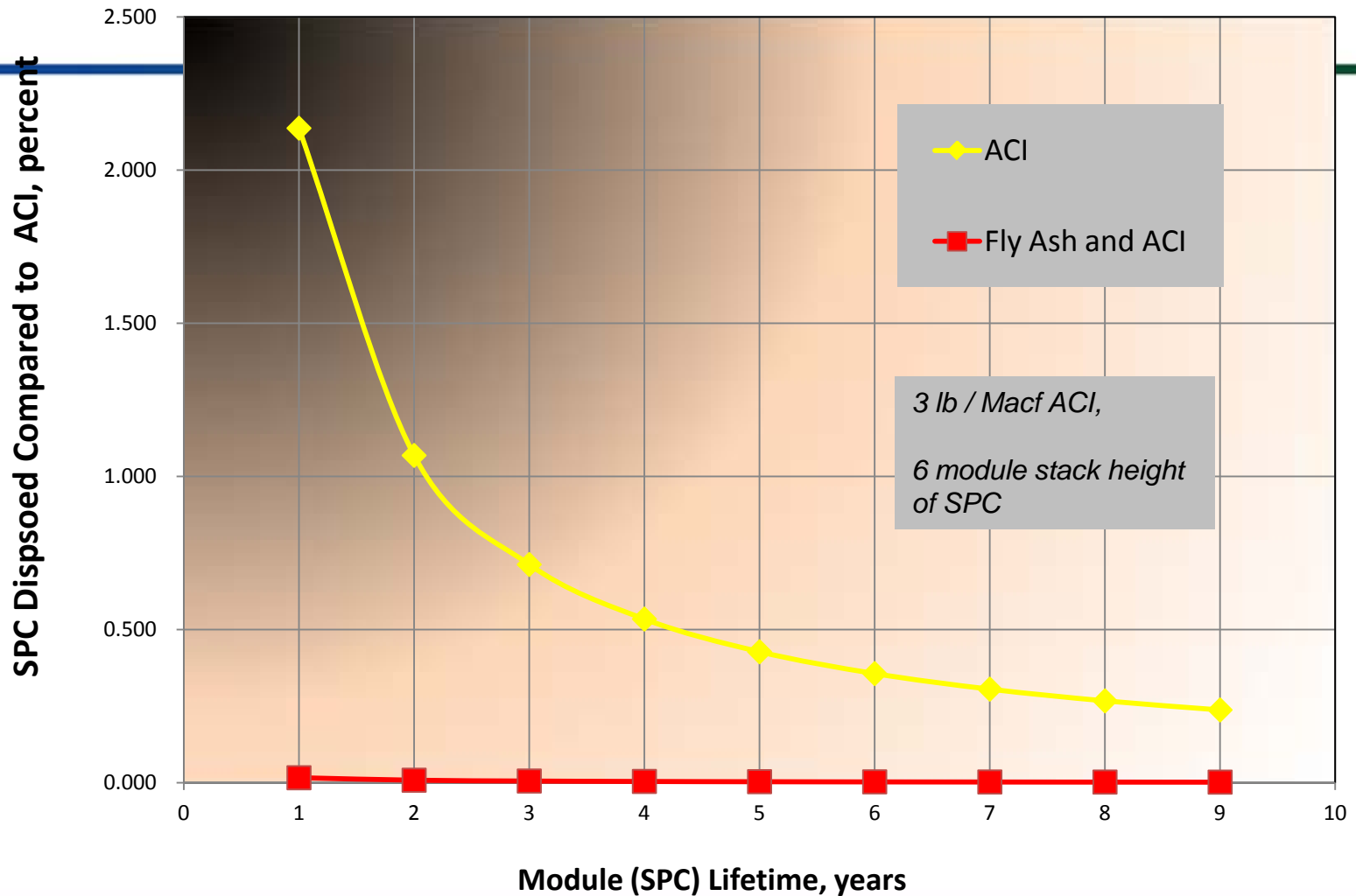

Gore System Upgrade Approach

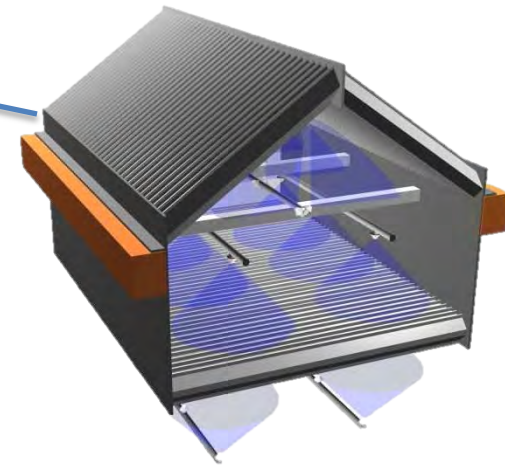
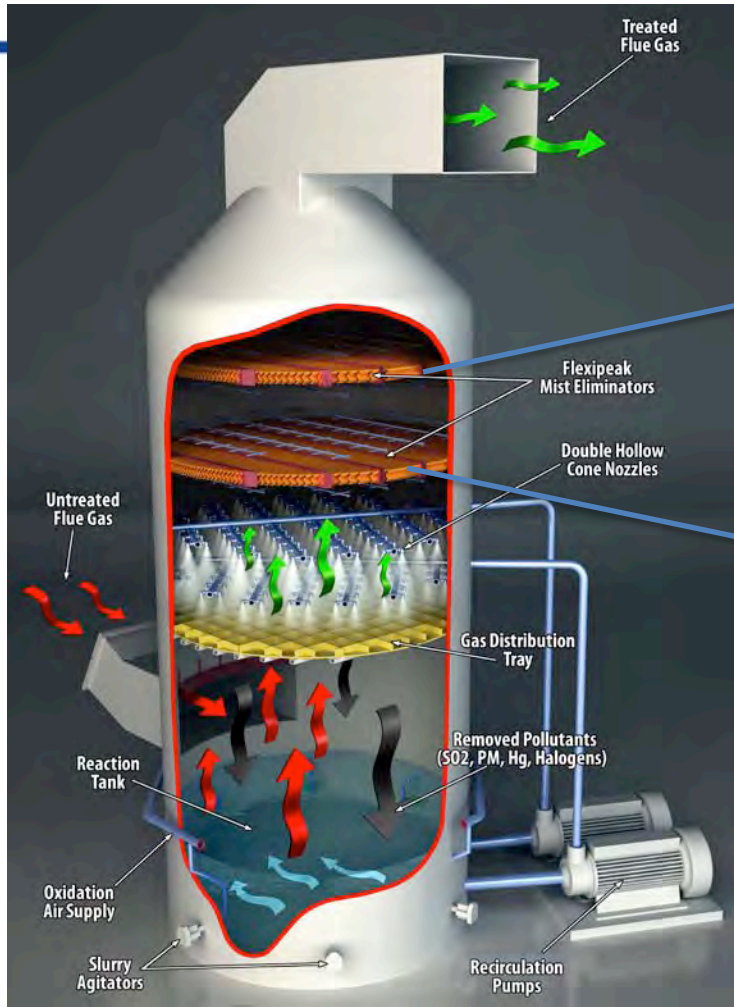

URS



2013 APC/PCUG Conference



Typical Upgrade Approach

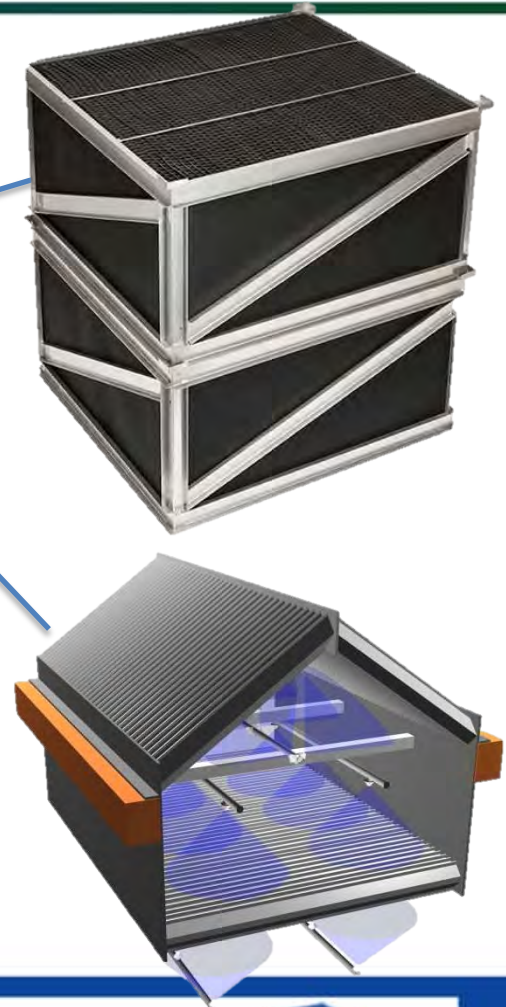
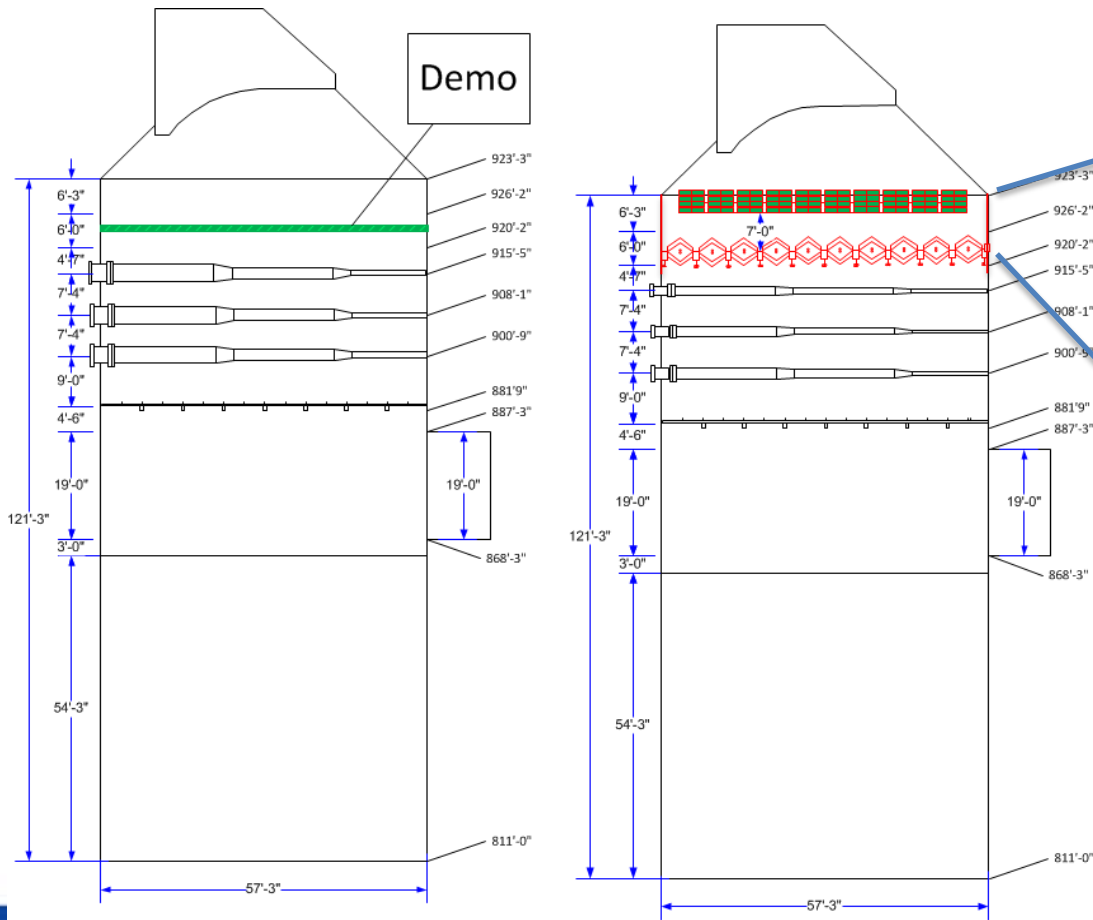

2013 APC/PCUG Conference



Typical Scope of Work

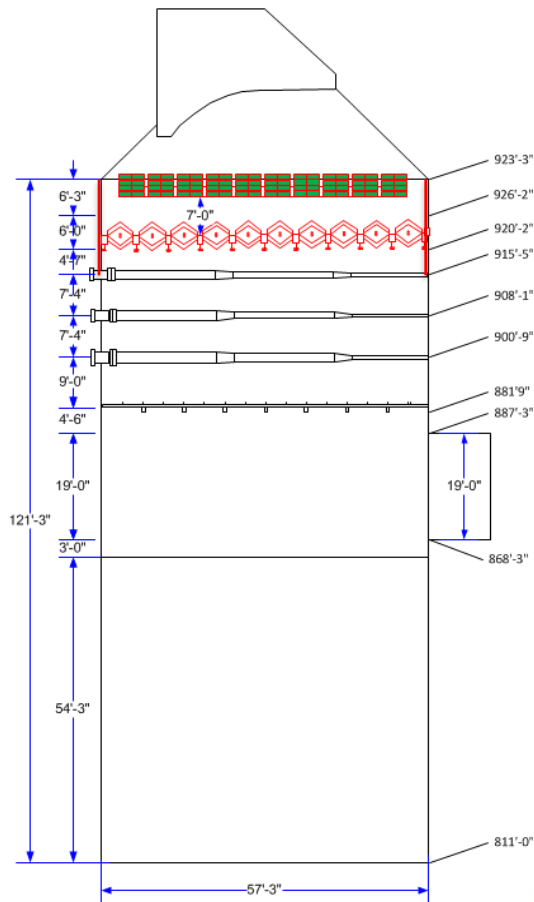

- Demolition
 - Current ME
- New Equipment
 - Mist eliminator
 - Mist eliminator beams
 - Mist eliminator wash headers
- Gore System
 - Gore modules
 - Gore beams
 - Wash header
 - Wash valves
- Absorber Wall Lining
 - Area between Gore modules and mist eliminator



Gore Module Support Structure

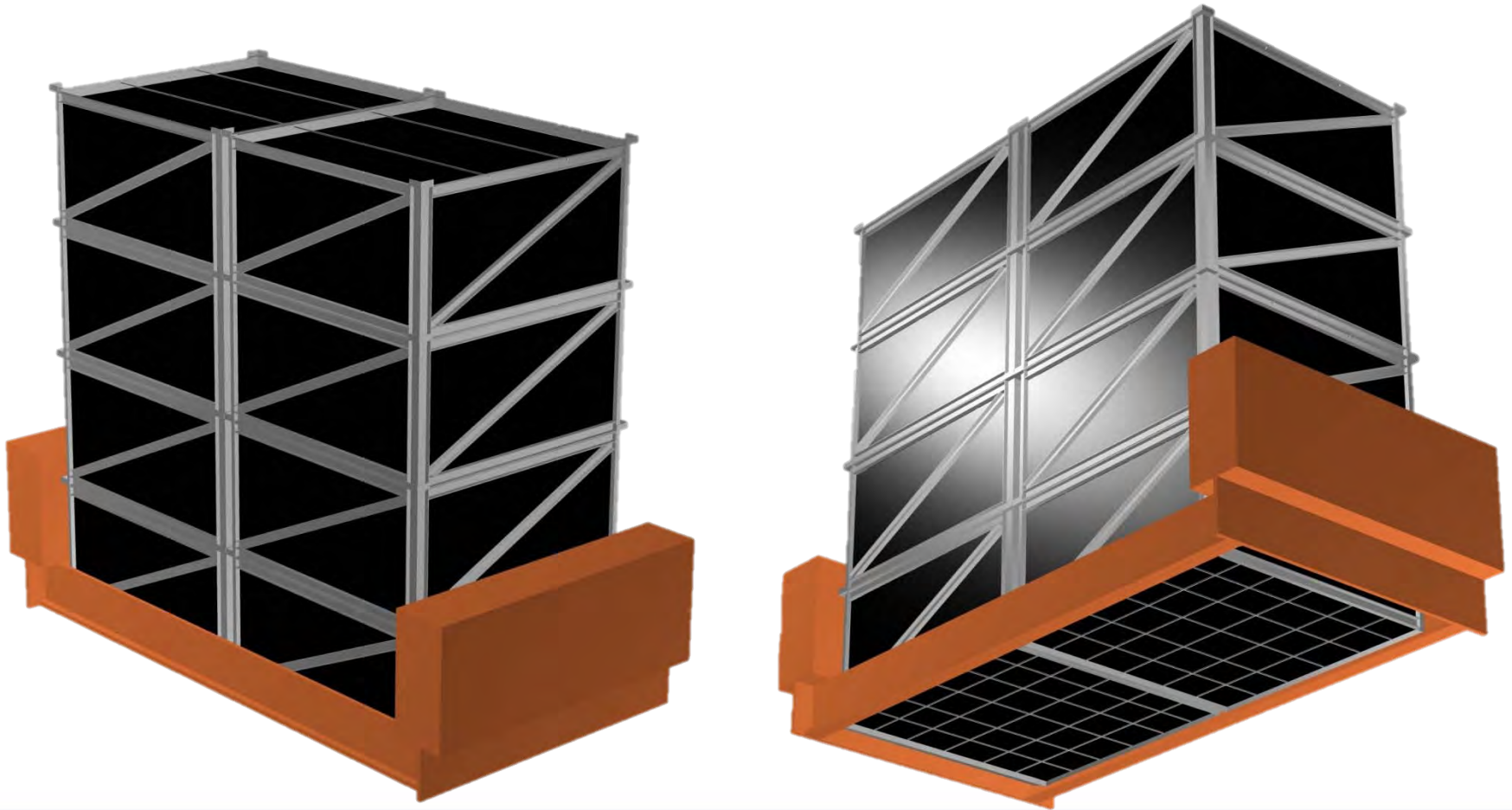

Typical Materials of Construction

Equipment	Material
Gore Module Frames	C276
Gore SPC	PTFE
Gore Support Beams	C276
Mist Eliminator Vanes	Polysulfone
Mist Eliminator Housing	HDPE
Mist Eliminator & Gore Wash Header	FRP
Mist Eliminator & Gore Wash Nozzles	Polysulfone
Mist Eliminator Hardware	C276
Absorber Lining	Epoxy or Flake glass

Pilot Testing Experience

- Minerals/Metals
 - 3 completed (4-12 months each)
 - 1 in progress, more in discussion
- Incinerators
 - 2 completed (1-4 months)
- Coal-Fired Power
 - 3 completed (8-12 months each)
 - 1 starting now
 - Several more under discussion



Coal Creek Pilot

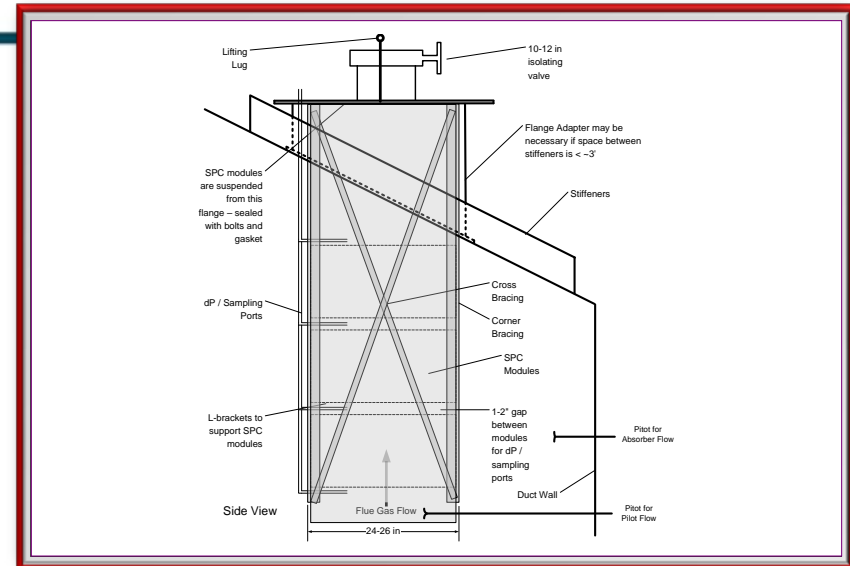
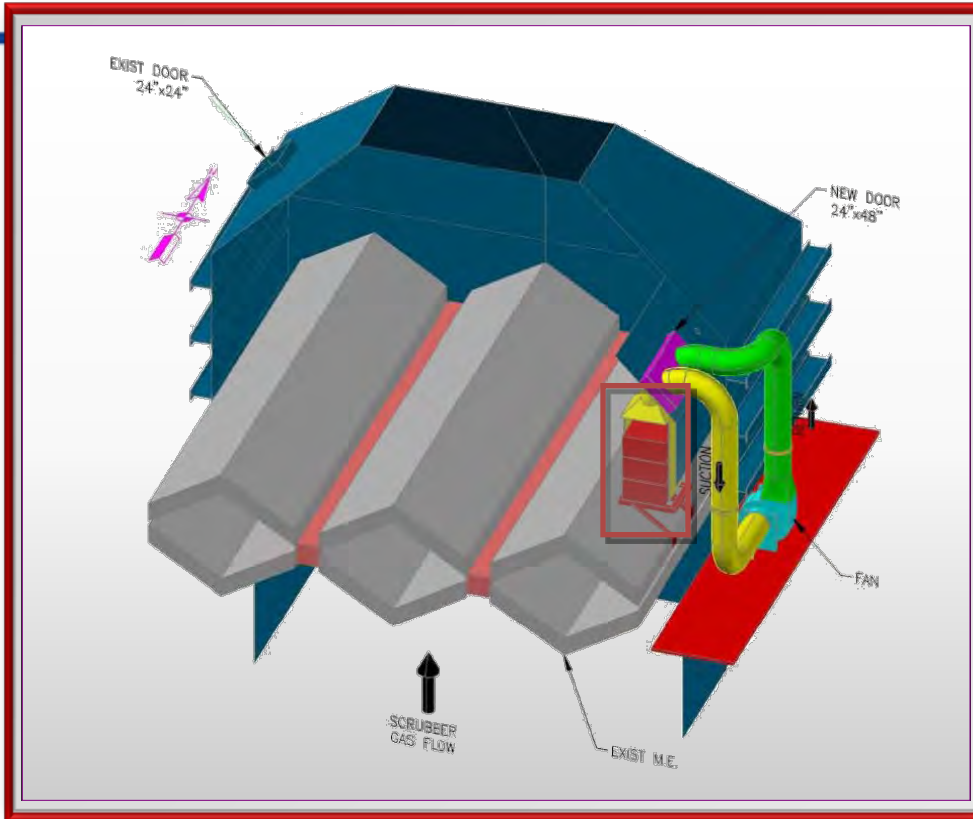

Experience full scrubber carry-over

Hg, SO_x, & ΔP measurements



Coal Creek Pilot



Three Module Stack



Mercury Removal – Coal Creek Pilot

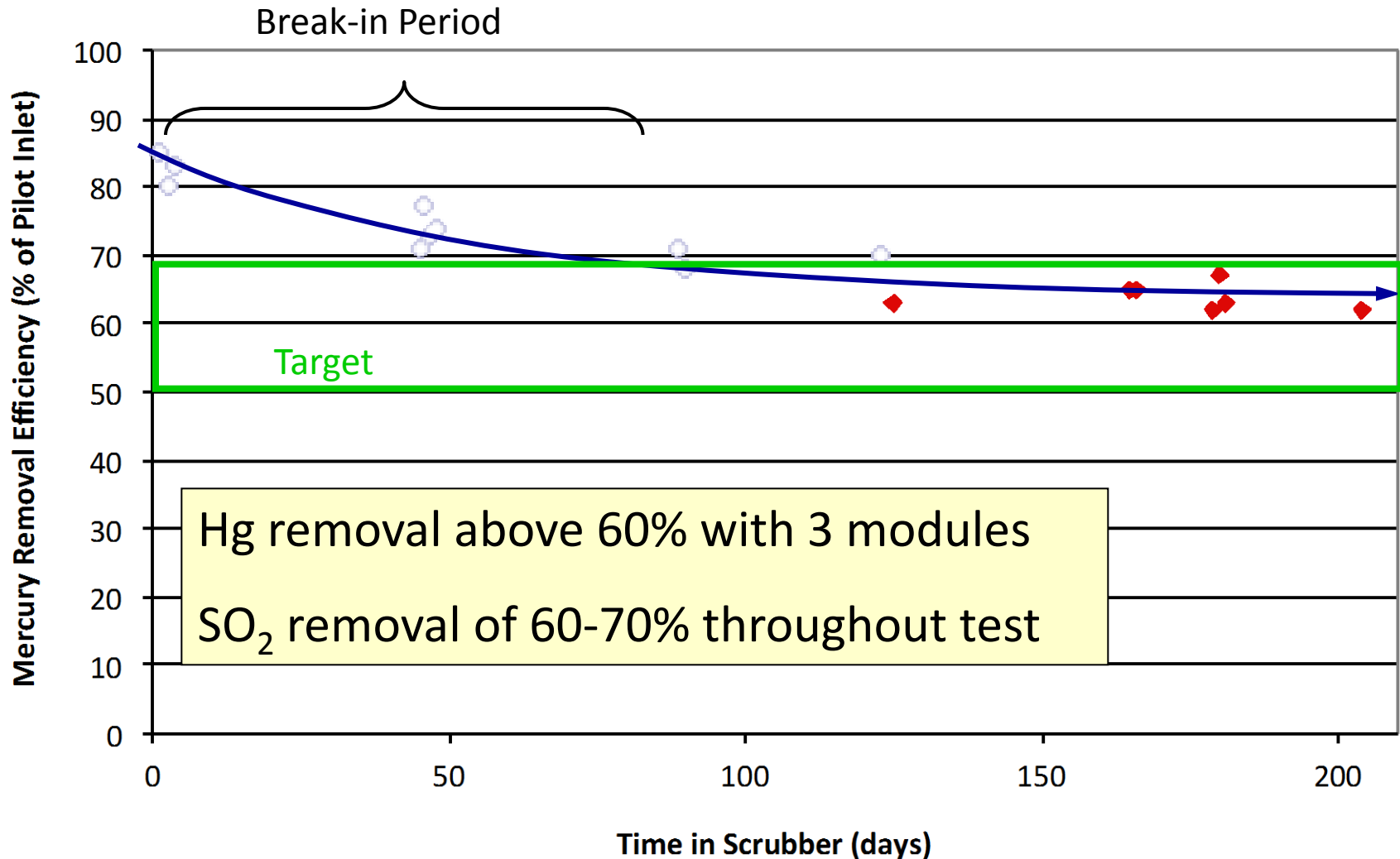

Pressure Drop Across the Coal Creek Pilot

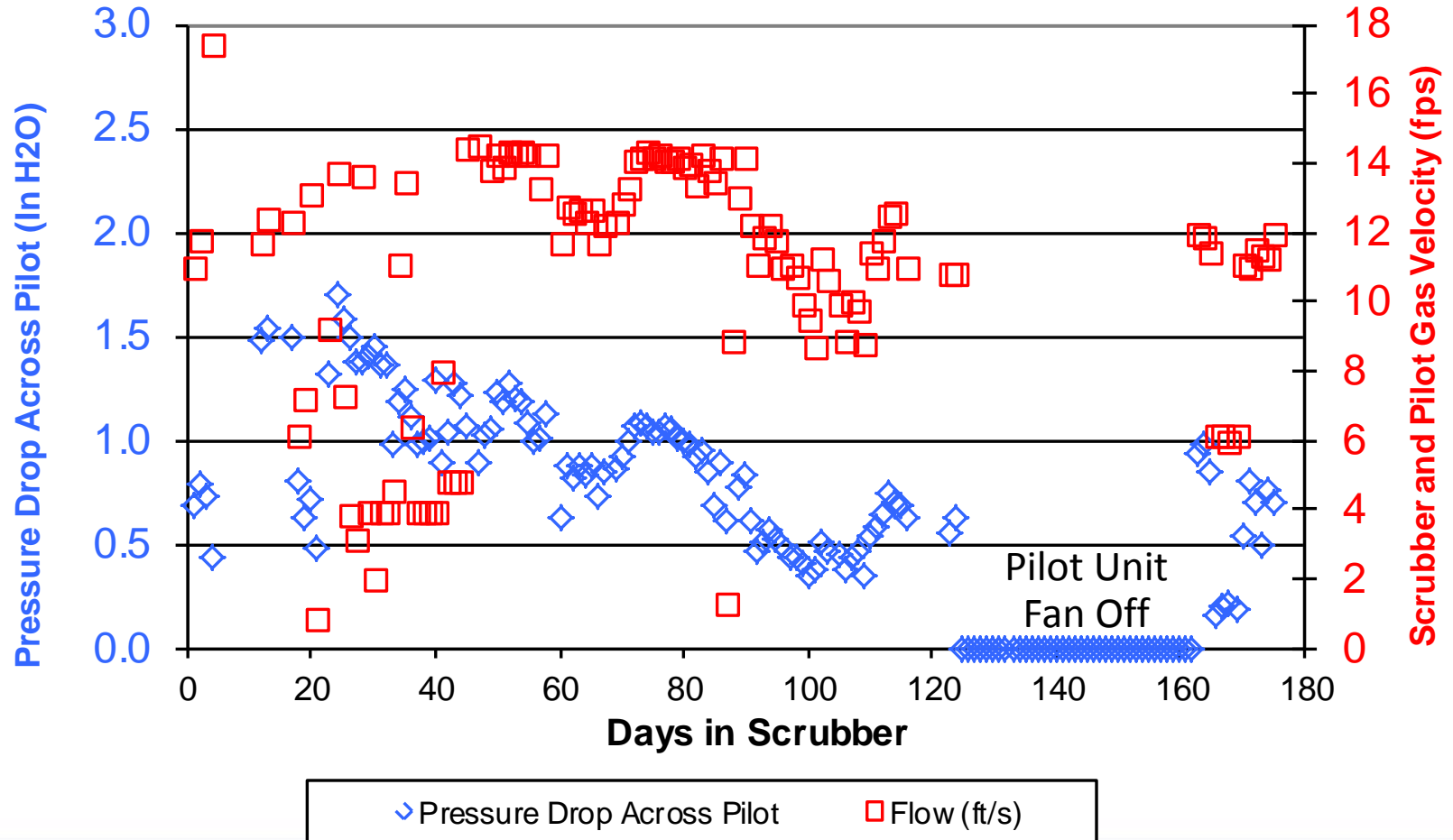

Modules in Operation (Coal Creek Pilot)



Leading Edge of Modules in operation
after ~200 days

Top View of Module Removed for
inspection



Hg Distribution in SPC

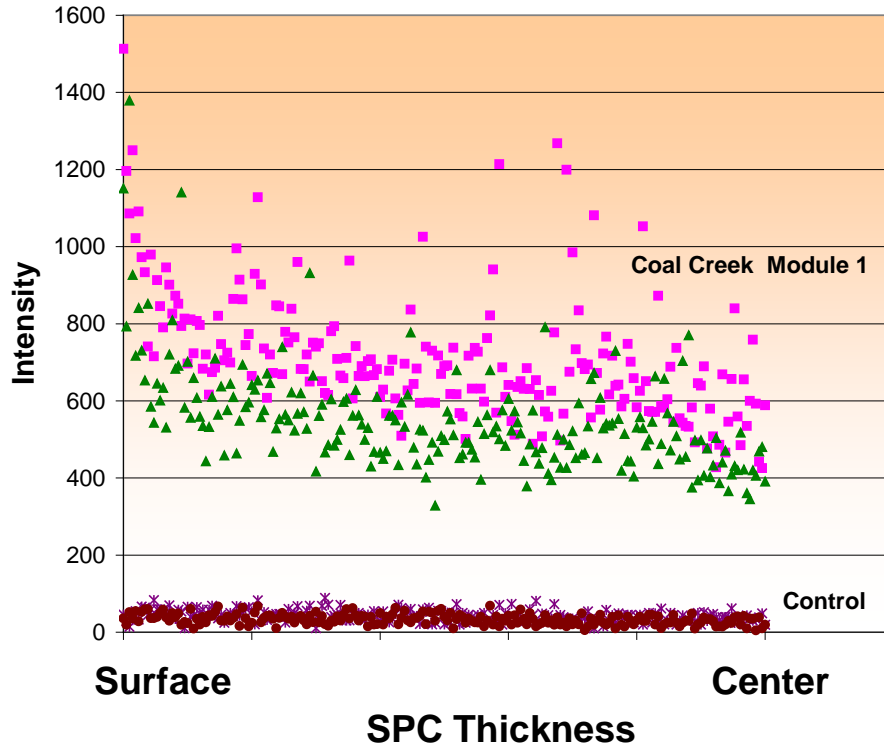

- SPC samples from Coal Creek field trial after 8 months of operation
- Laser ablation / ICP-MS
- Mercury penetrates all the way to the center of the SPC tape thickness
- Minimal surface concentration



New Pilot Test

6-module stack installed
~5' above ME

Forced oxidation
limestone gypsum
scrubber

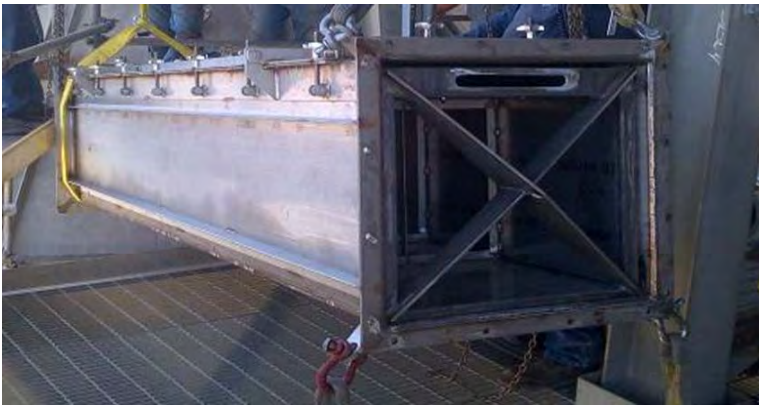
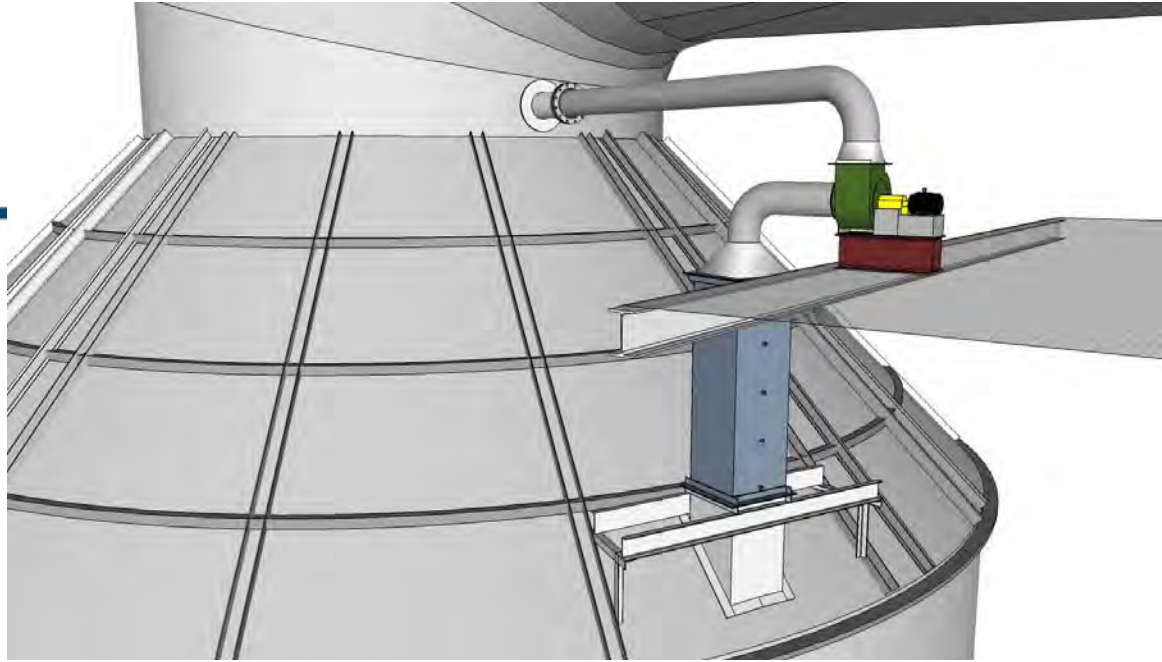

Starting up now
(July 2013)

Plan to run for at
least 1 year

URS



2013 APC/PCUG Conference



Sherco Overview

- 1,394 MW
 - Unit 1 – 765 MW, 1976
 - OFA, LNB, WFGD (12 vessels), Wet ESP
 - Unit 2 – 765 MW, 1977
 - OFA, LNB, WFGD (12 vessels), Wet ESP
 - Unit 3 – 900 MW, 1987 DFGD
- PRB Fuel

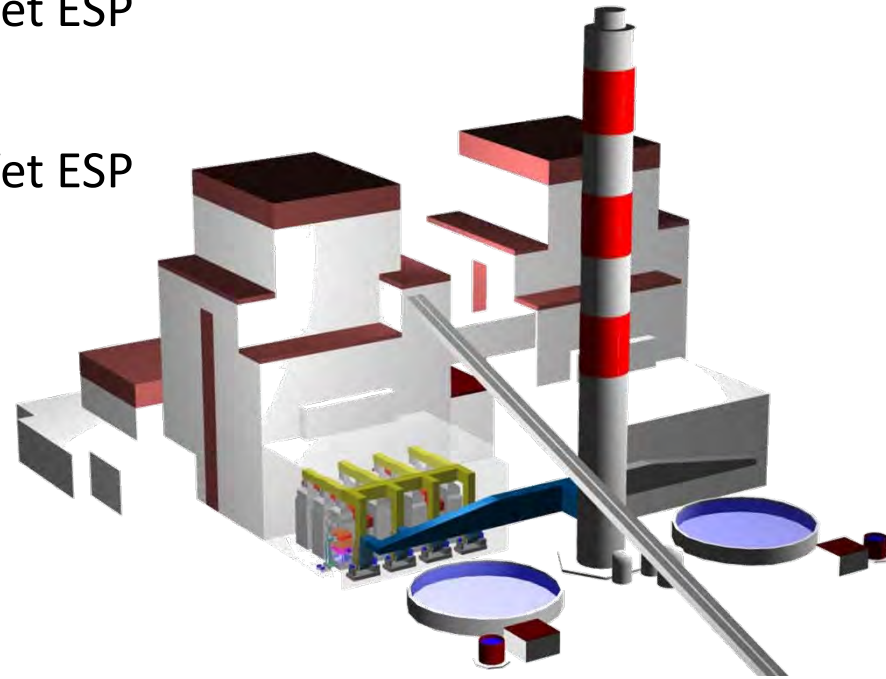

Sherco Absorber Design

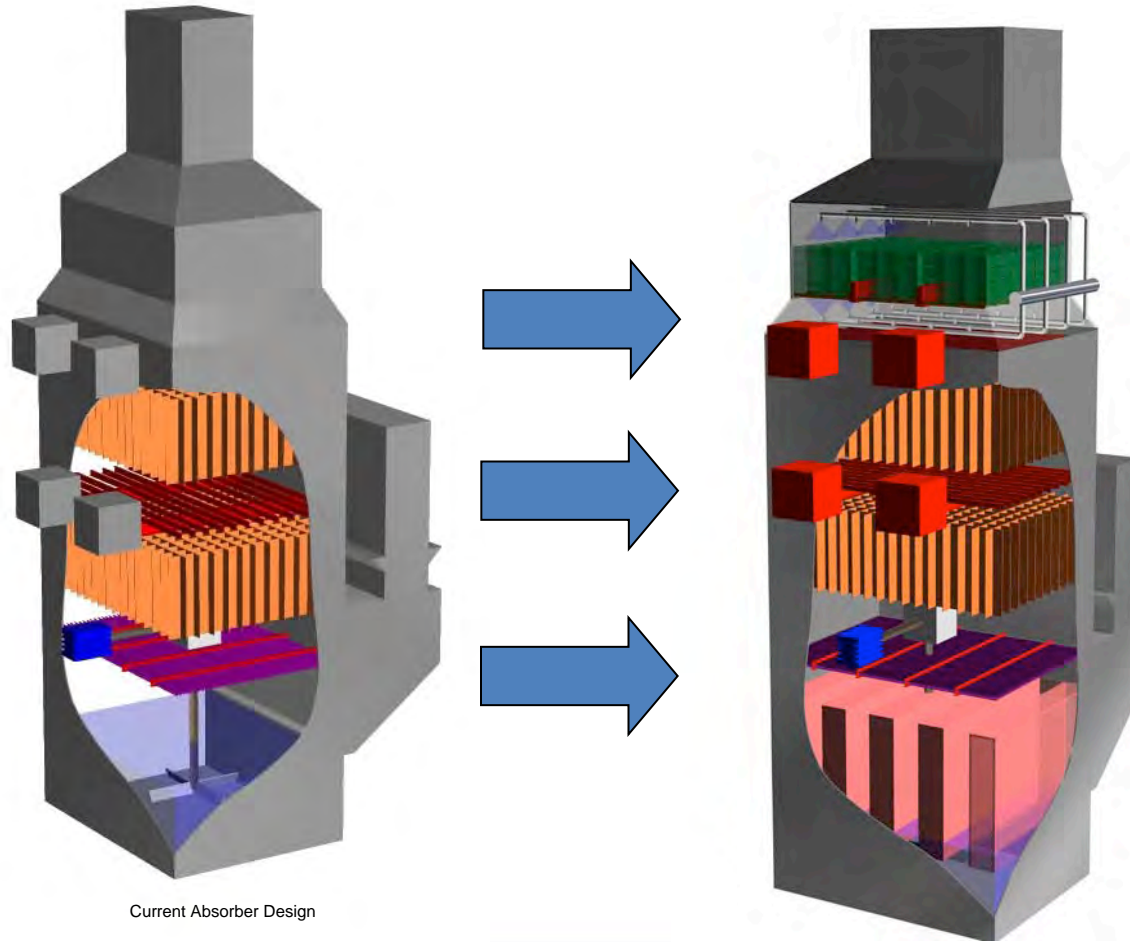

Current Absorber Design

Module Installation – 216 Modules

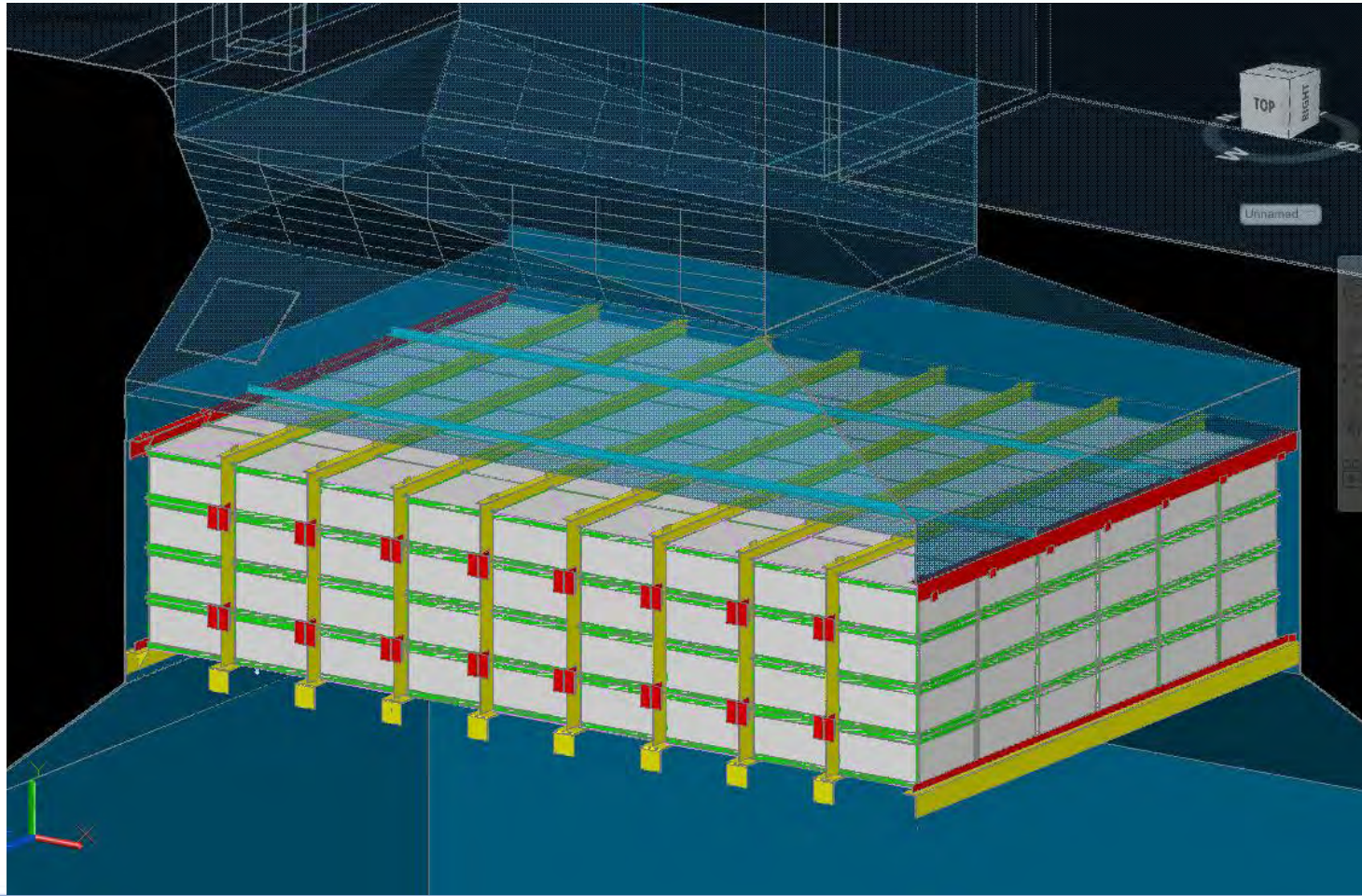

Previous Configuration



Installation of Beams & Modules

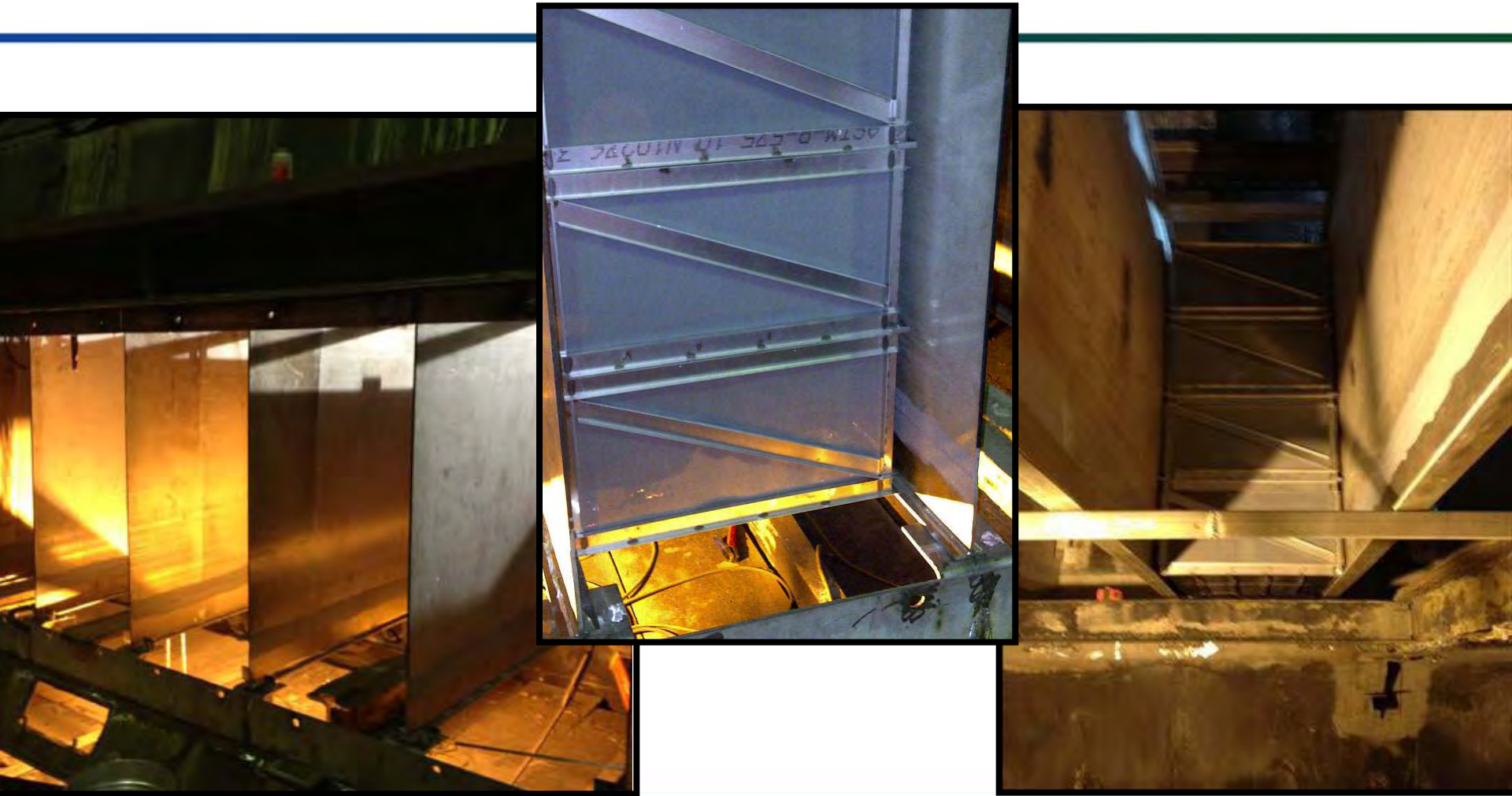

Sherco Path Forward

- Start-up Mid July 2013
- Verify Hg Compliance Target
 - Less than 1.0 lb/TBtu
- Expected to Run for One Year
 - If successful, remaining 23 absorber vessels will be upgraded



Conditions Favoring GMCS

- ACI / DSI
 - High sulfur coals (SO_3 interference with ACI)
 - Combination of ACI and DSI is required (capital intensive)
 - ESP upgrade required from ACI or ACI/DSI (capital intensive)
 - High temperature ESP (ACI and DSI ineffective)
 - Fly ash is currently sold
- Bromides
 - High sulfur coals (Bromides much less effective)
 - Lower FGD alloy used (Br^- corrosion)
 - APH operating close to acid dew point (APH corrosion)
 - No SCR present (necessitates high bromine injection rates)
 - Plant has a liquid discharge (bromides release Selenium which ends up in the liquid phase)
- FGD
 - FGD upgrade is required (built-in no cost FGD upgrade with GMCS)
 - Hg reemission is a problem (built-in with the GMCS)
 - Reduction in particulate emissions required (built-in no cost mist collection with the GMCS)

Operating Cost- 600 MWe Plant

No Fly Ash Sales

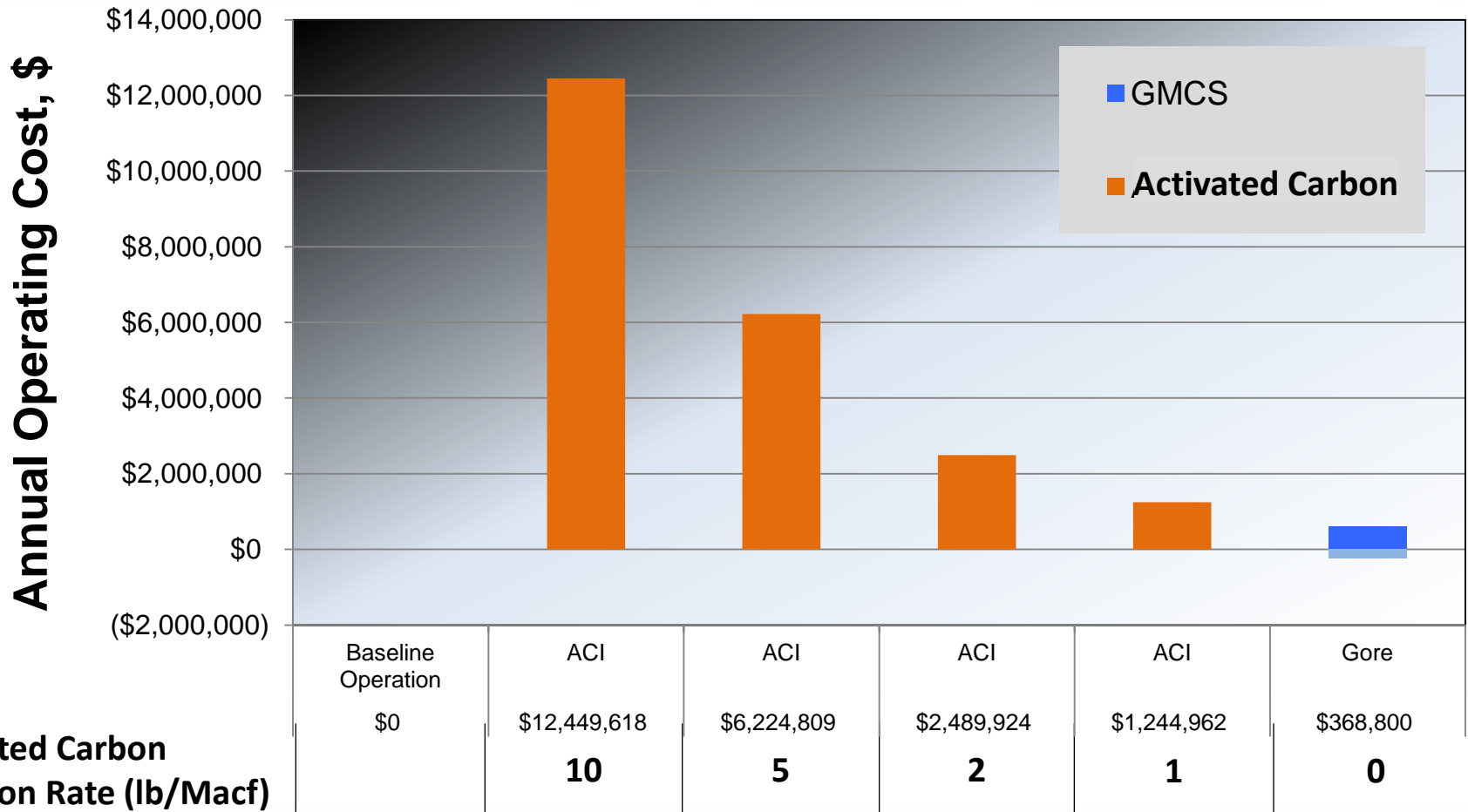

Operating Cost- 600 MWe Plant

Fly Ash Sales

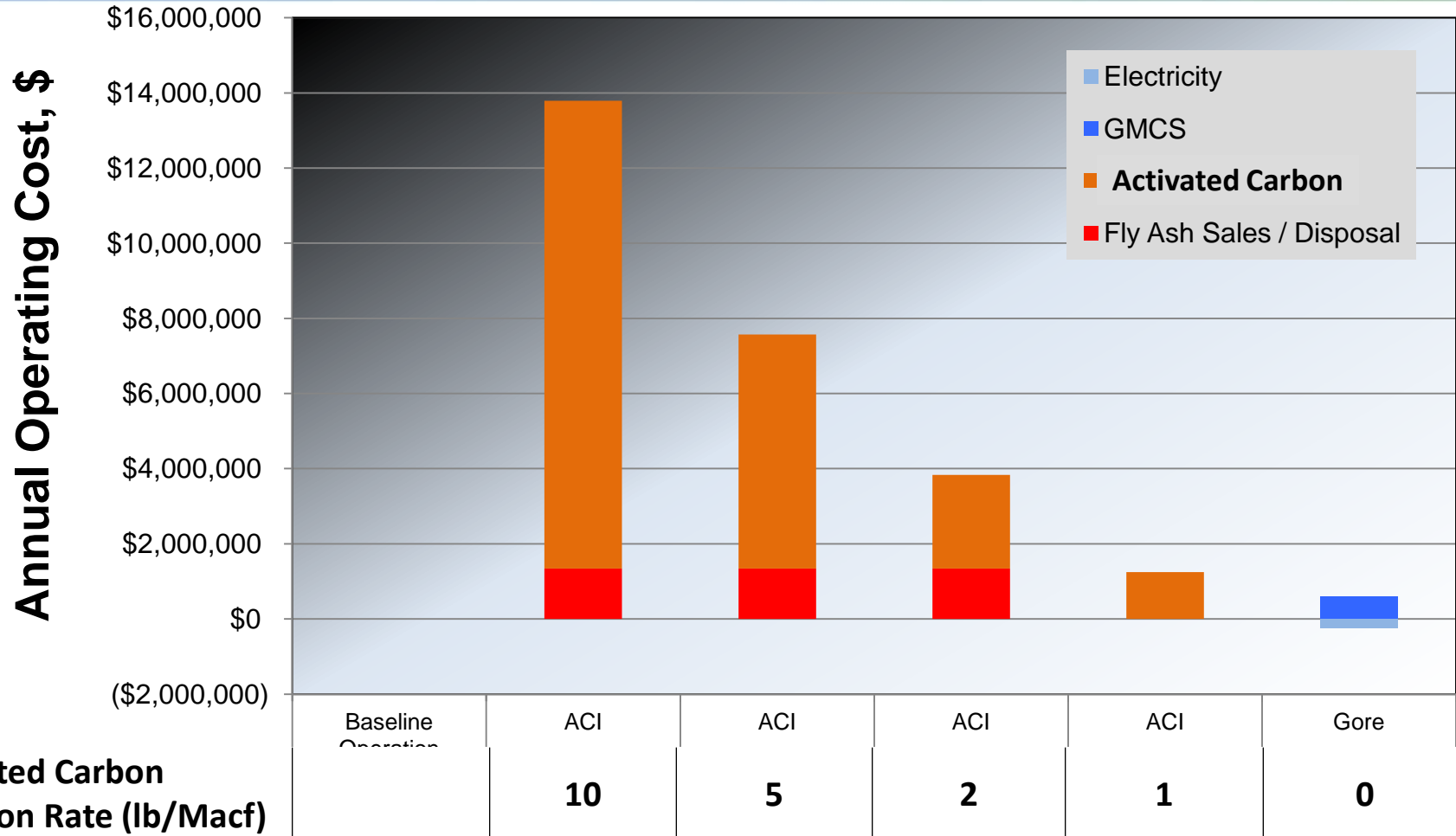

2013 APC/PCUG Conference



Operating Cost- 600 MWe Plant

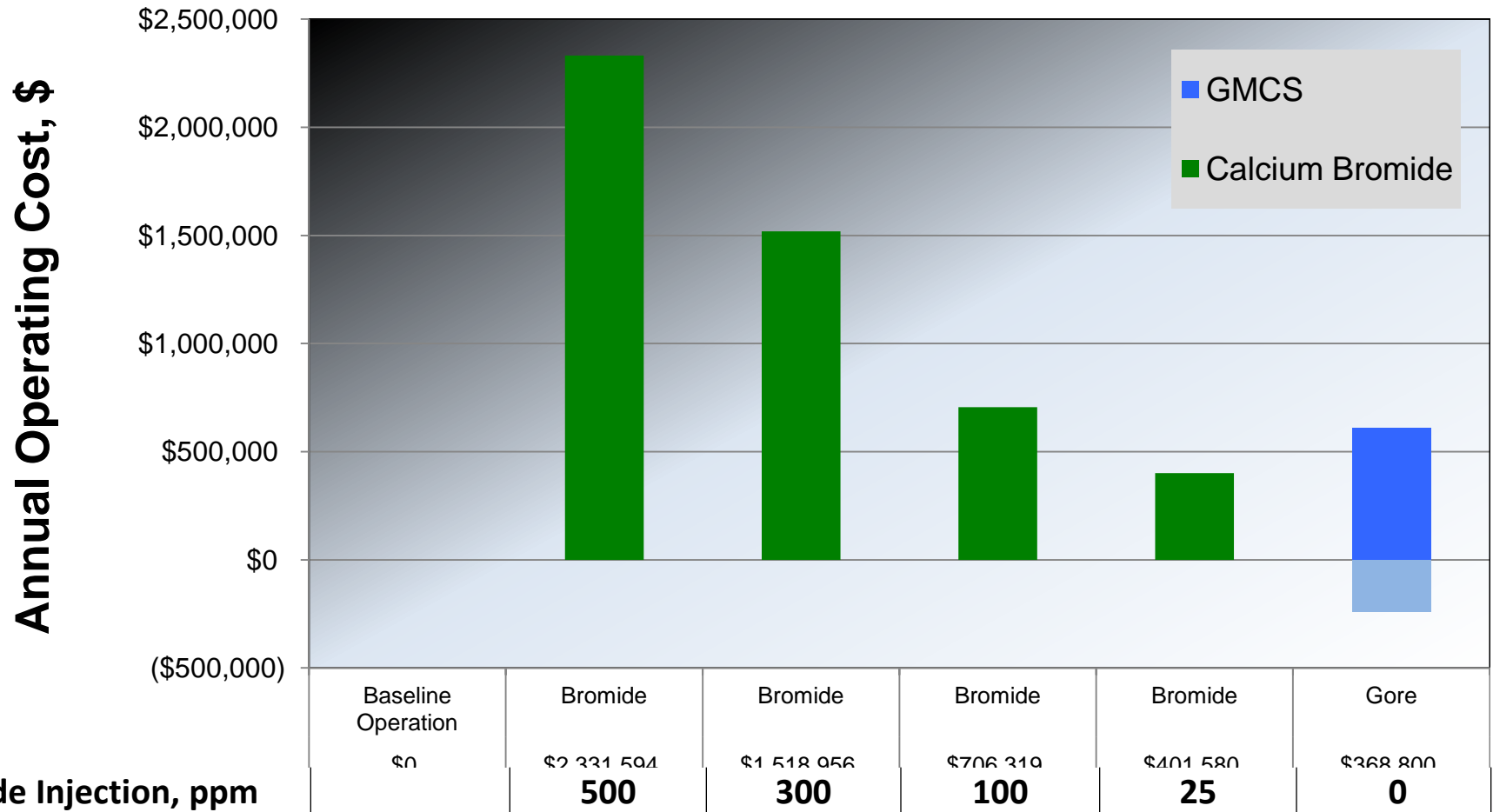

2013 APC/PCUG Conference



Capital Cost

Technology	Cost	Low	Average	High
ACI	\$/kW	5	8	15
DSI	\$/kW	5	8	15
Bromides	\$/kW	5	5	5
FGD Upgrade	\$/kW	10	25	50
ESP Upgrade	\$/kW	10	25	50
Gore*	\$/kW	20	25	30

*Includes new Mist Eliminator and Scrubber Upgrade (SO₂)



Sensitivity - Life of Gore Modules

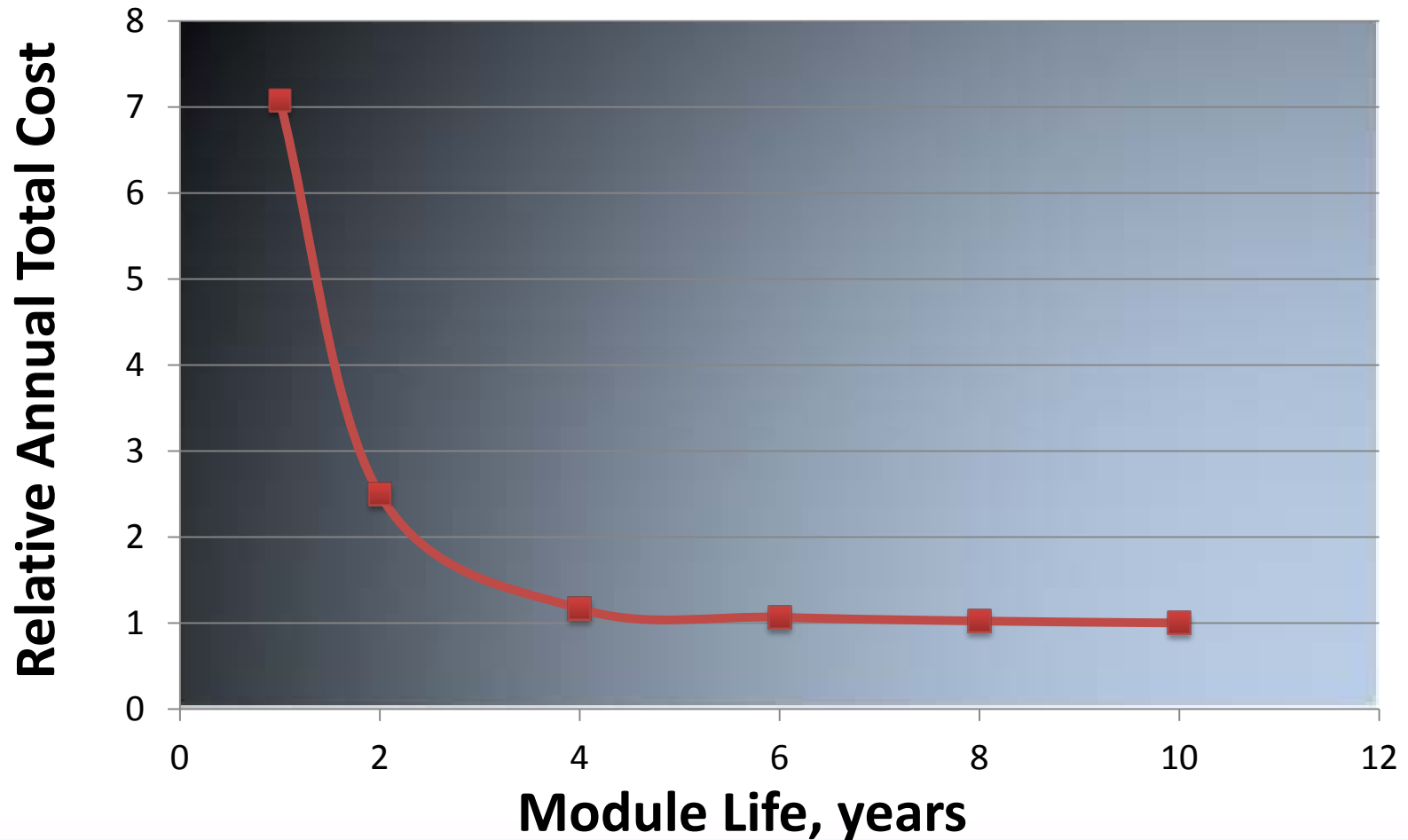

Volatility of Commodities

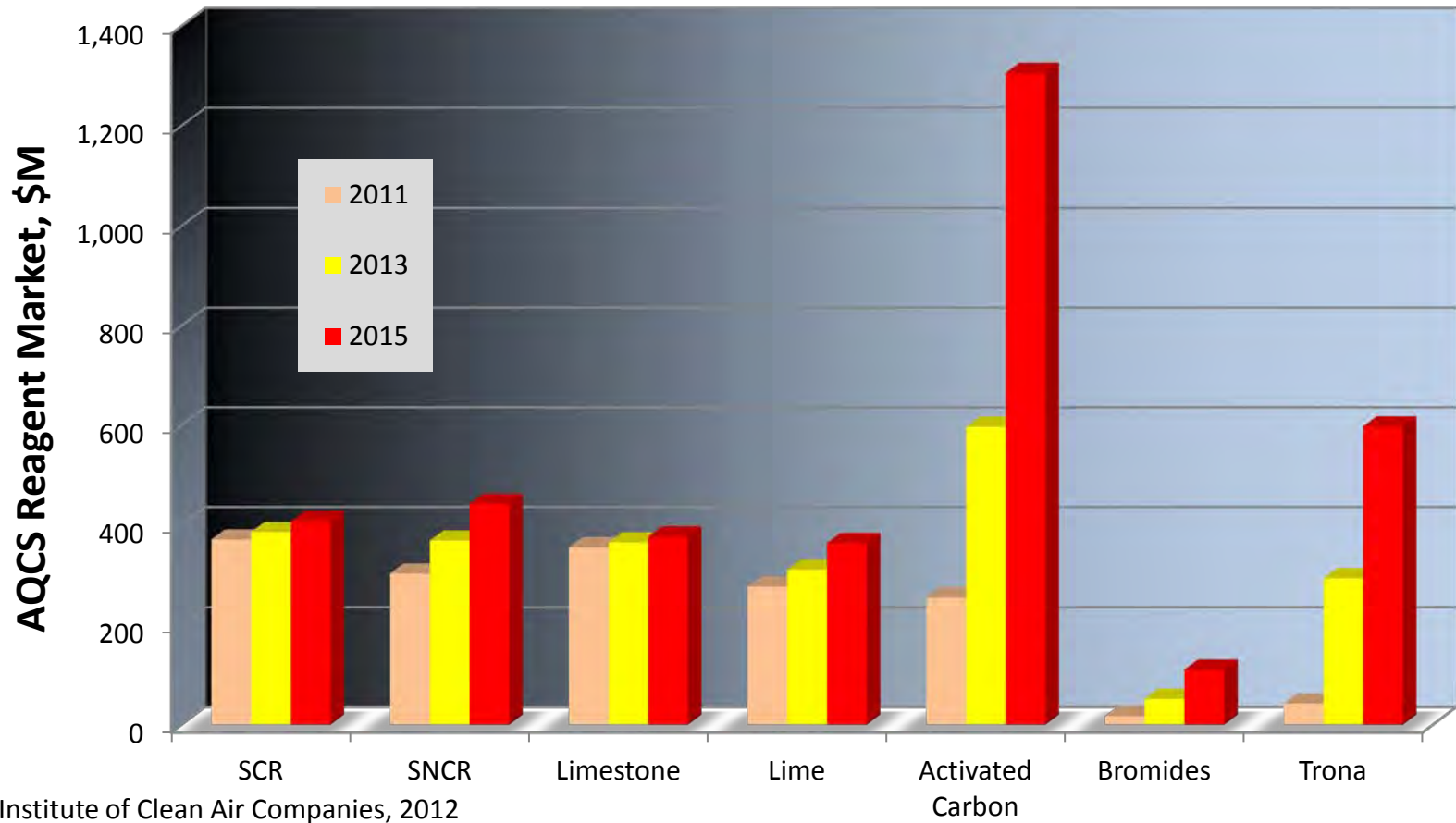

Sensitivity of Activated Carbon Price

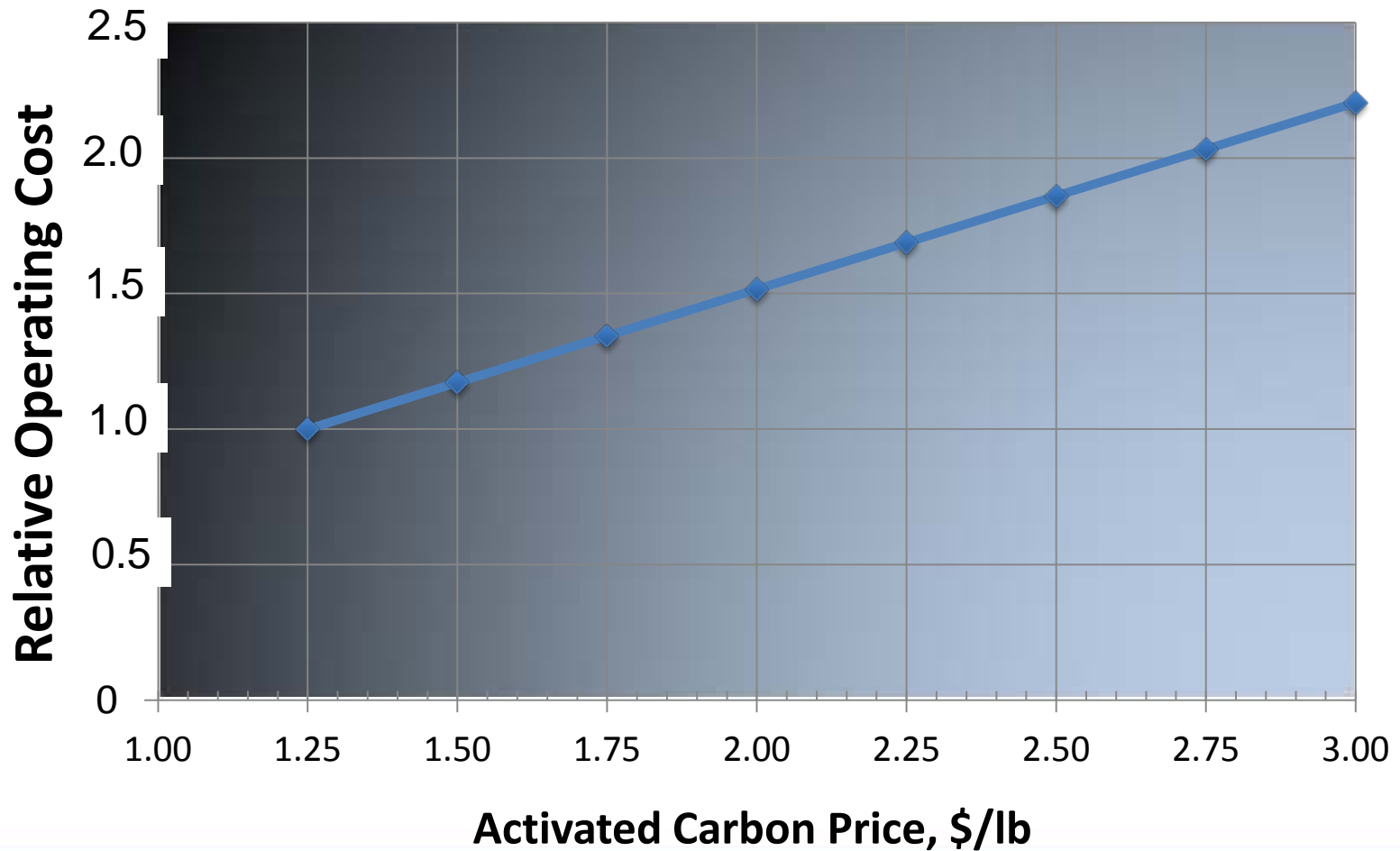

Diminishing Returns with Injection

- Injection Systems such as ACI or Bromides typically show similar behavior in terms of removal efficiency

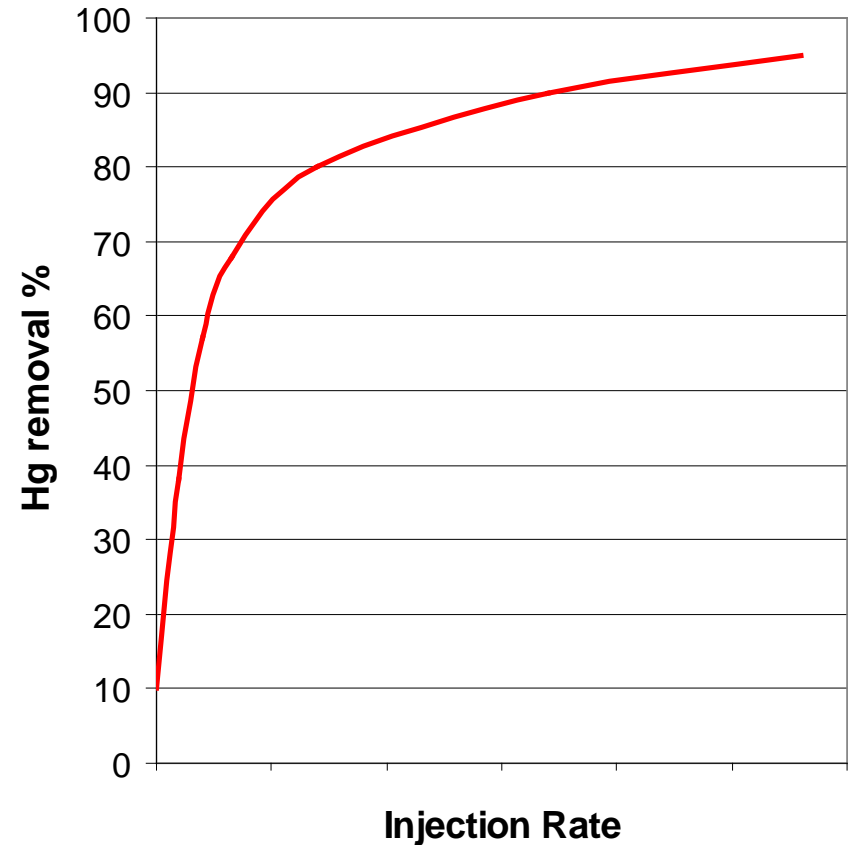

Diminishing Returns with Injection

- Injection Systems such as ACI or Bromides typically show similar behavior in terms of removal efficiency
 - Easy to achieve initial 20-40% Hg removal

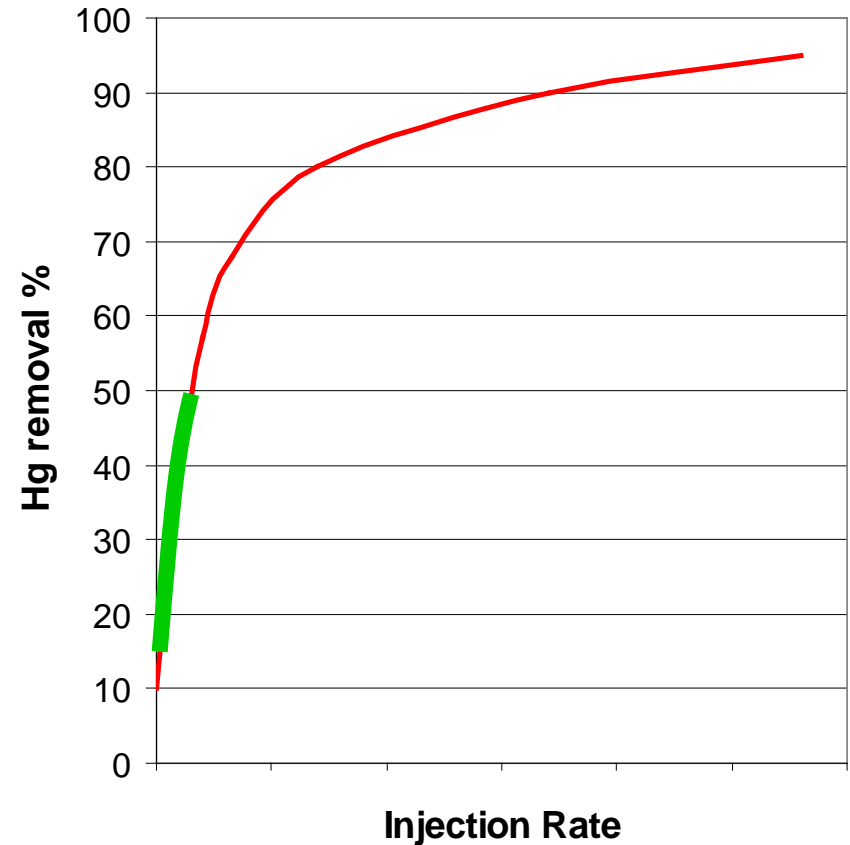

Diminishing Returns with Injection

- Injection Systems such as ACI or Bromides typically show similar behavior in terms of removal efficiency
 - Easy to achieve initial 20-40% Hg removal
 - Difficult to achieve the last 20-40% Hg removal

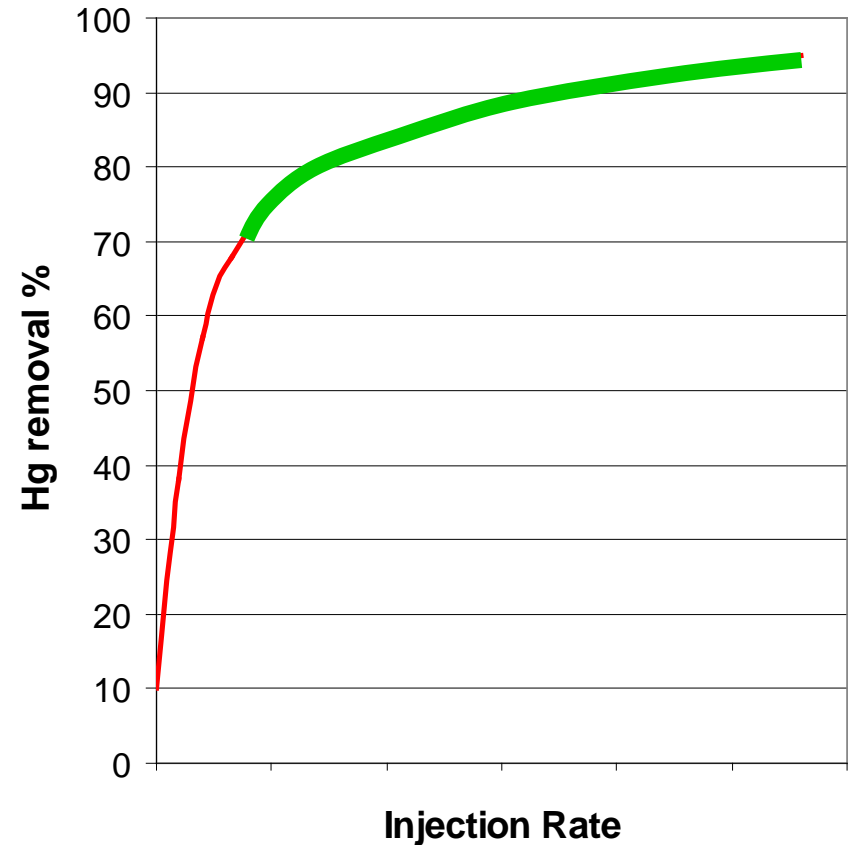

Diminishing Returns with Injection

- Injection Systems such as ACI or Bromides typically show similar behavior in terms of removal efficiency
 - Easy to achieve initial 20-40% Hg removal
 - Difficult to achieve the last 20-40% Hg removal
- Result: high operating cost for plants that have significant Hg reduction needs

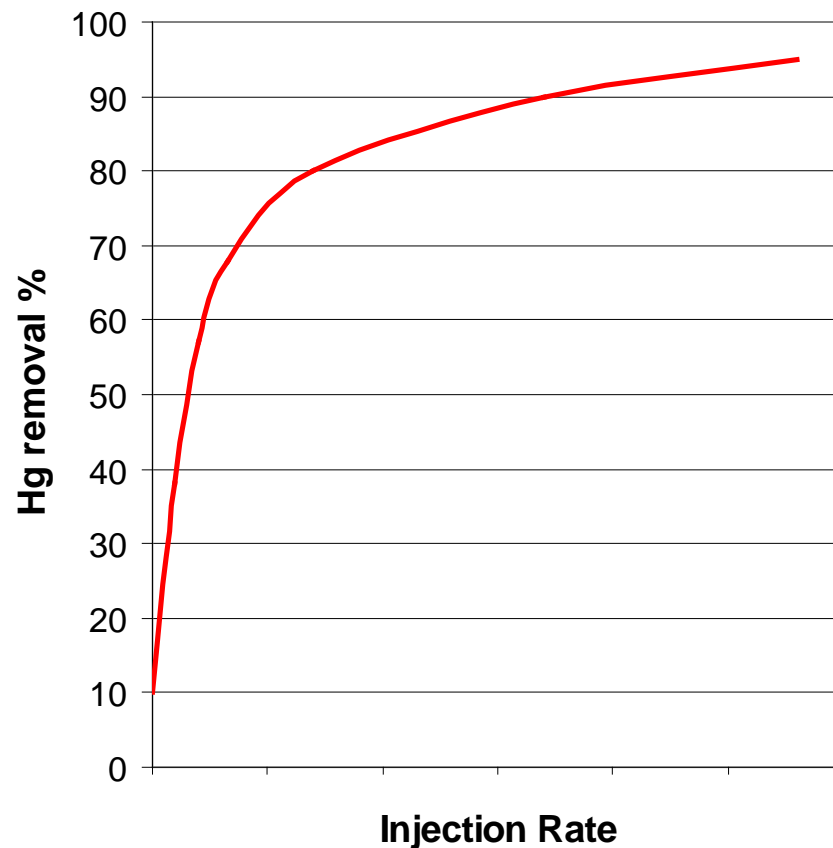

Diminishing Returns with Injection

- Injection Systems such as ACI or Bromides typically show similar behavior in terms of removal efficiency
 - Easy to achieve initial 20-40% Hg removal
 - Difficult to achieve the last 20-40% Hg removal
- Result: high operating cost for plants that have significant Hg reduction needs

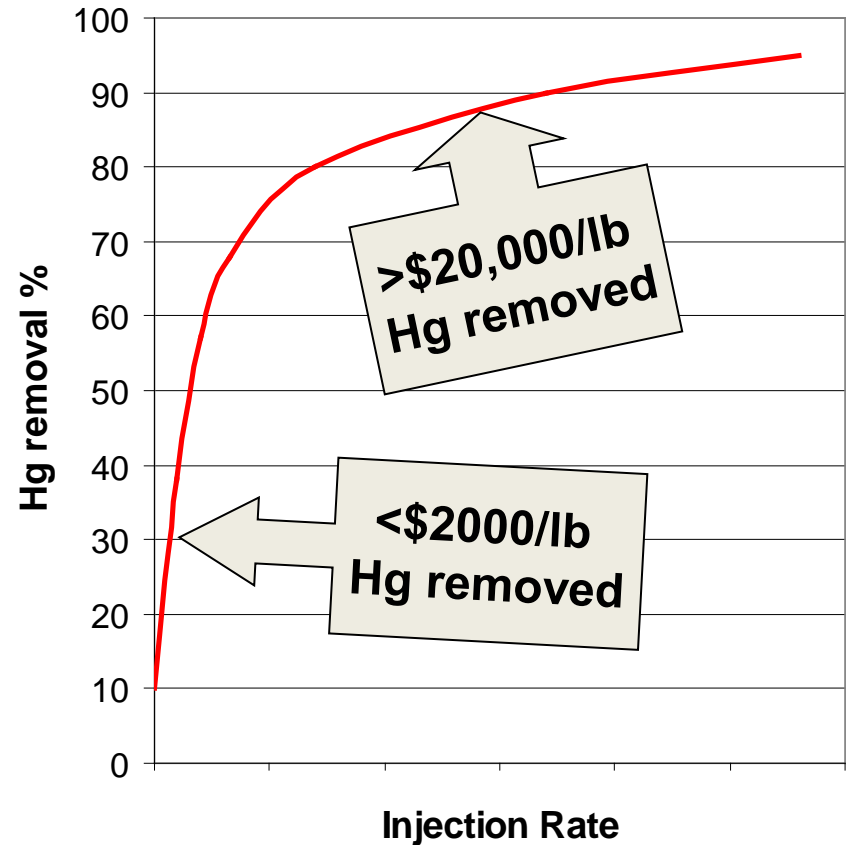

Diminishing Returns with Injection

- Additional concern over high reagent usage
 - ACI:
 - Fly ash contamination
 - Overloading ESP
 - Bromine
 - APH Corrosion
 - Wastewater treatment issues

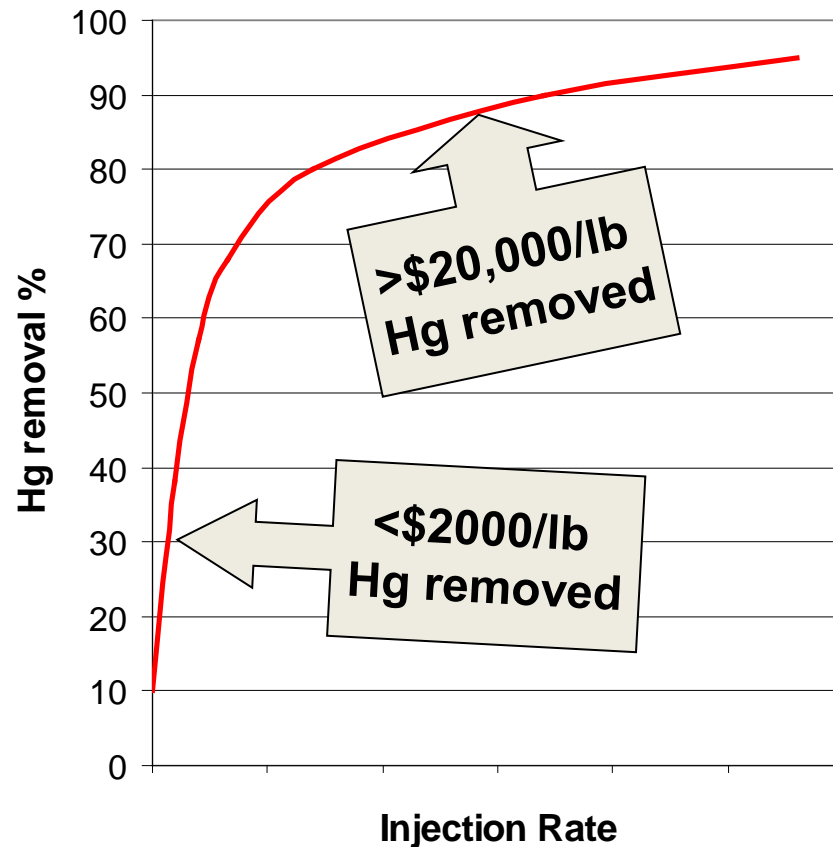

Fixed Sorbent System

- Fixed Sorbent System has a **constant \$/lb** mercury removed
 - Sorbent remains in flue gas until it reaches capacity for Hg capture
 - Very cost-effective solution for achieving high mercury removal
- Can work in complementary fashion with an injection system (i.e., if an injection system already exists, space constrained scrubber)
 - Use injection system for “easy-to-get” mercury
 - Injection system is always upstream of fixed sorbent system
 - Use fixed sorbent system for “difficult-to-get” mercury
- Economics support allowing the fixed sorbent system to carry most or all of the burden



Hybrid Scenarios

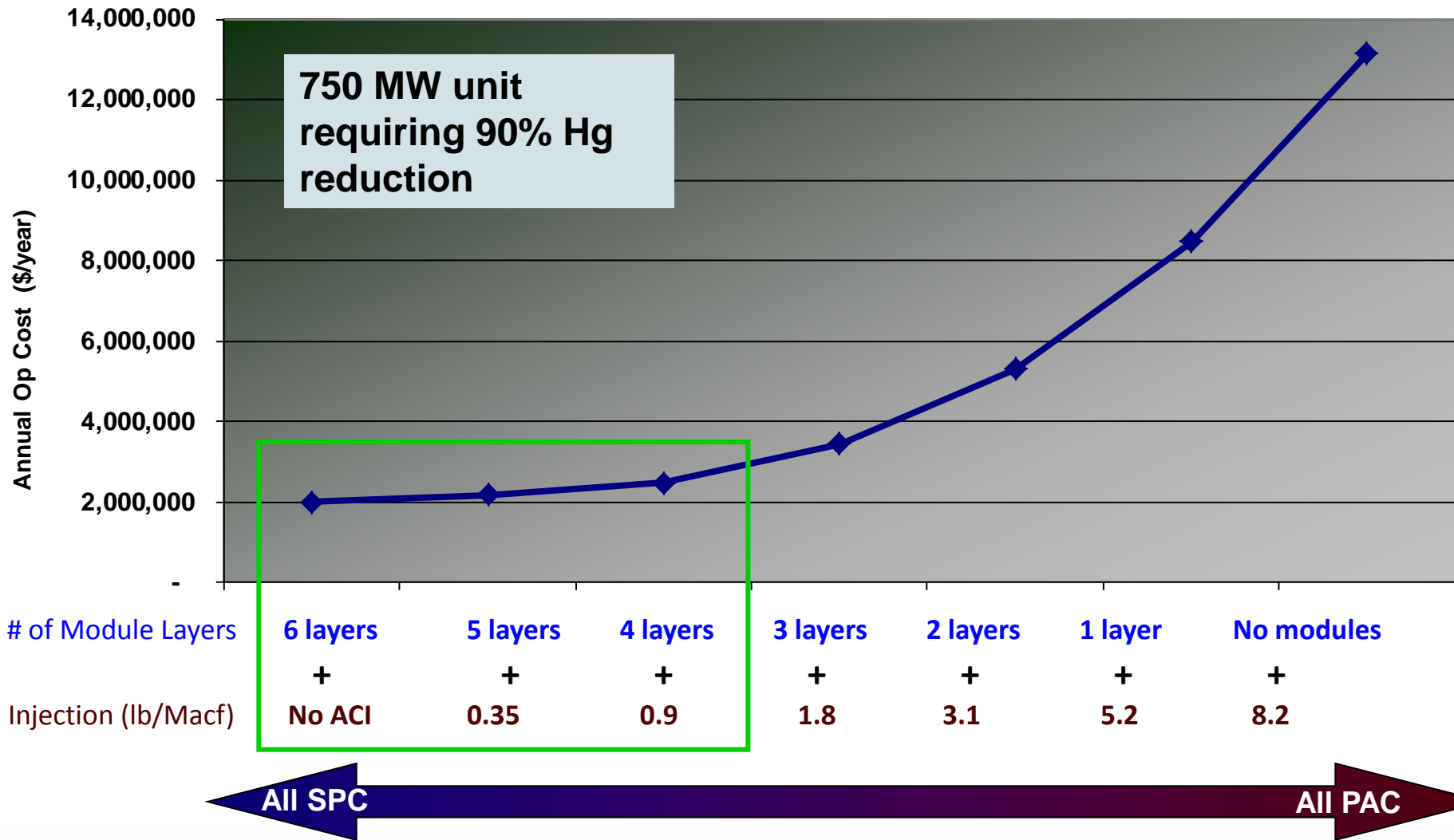

Future Activities

- Several new pilot tests in 2013
- Start-up Xcel full-scale demonstration July 2013
- Multiple commercial installations starting early 2014
- Continuing technology advancements
 - Future generations of modules with higher performance
 - Maximizing value of co-benefits
 - New installation approaches
- High volume module production



Module Production

- High volume module production operational 4Q 2013
 - Gore's Maryland plants
- High demand expected starting in early 2014 through 2016
 - MATS Compliance Solution
- After 2016: Plants seeking operating cost reduction from reagent usage

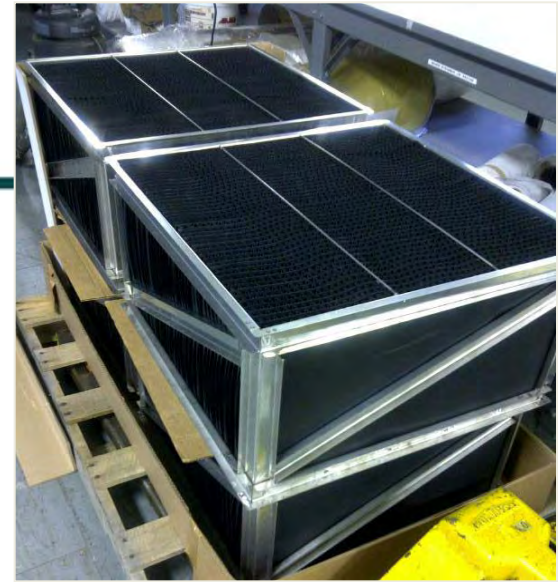

Conclusions

- GMCS fixed sorbent system is a new approach to mercury control
 - Eliminates many of the concerns associated with traditional mercury control systems
 - Low impact, simple, and robust
- Co-benefits provide additional value
- Commercial installations in 2014
 - Full-scale
 - Offered with strong guarantees



Thank You!



*Creative Technologies
Worldwide*



2013 APC/PCUG Conference

